

INDEX TO DRAWINGS	
SHEET NO.	DESCRIPTION
1	TITLE SHEET
2	STANDARD PLANS SUMMARY
3 - 4	GENERAL NOTES AND LEGEND
5 - 8	WATER POLLUTION & EROSION CONTROL NOTES
9 - 20	GUARDRAIL DETAILS
21 - 30	ROADWAY PLANS (BASE BID)
31 - 37	ROADWAY PLANS (ADDITIVE ALT. #1)
38 - 39	GUARDRAIL SUMMARY
40	WORK ZONE SIGNING PLAN, NOTES & DETAILS

STATE OF HAWAII
DEPARTMENT OF TRANSPORTATION
HIGHWAYS DIVISION
HONOLULU, HAWAII

PLANS FOR
**HONOAPIILANI HIGHWAY
GUARDRAIL AND SHOULDER IMPROVEMENTS**
VICINITY OF NORTH KIHEI ROAD TO HONONANA
FEDERAL-AID PROJECT NO. STP-030-1(058)R
DISTRICTS OF LAHAINA AND WAILUKU
ISLAND OF MAUI

FED. ROAD DIST. NO.	STATE	FED. AID PROJ. NO.	FISCAL YEAR	SHEET NO.	TOTAL SHEETS
HAWAII	HAW.	STP-030-1(058)R	2023	1	40

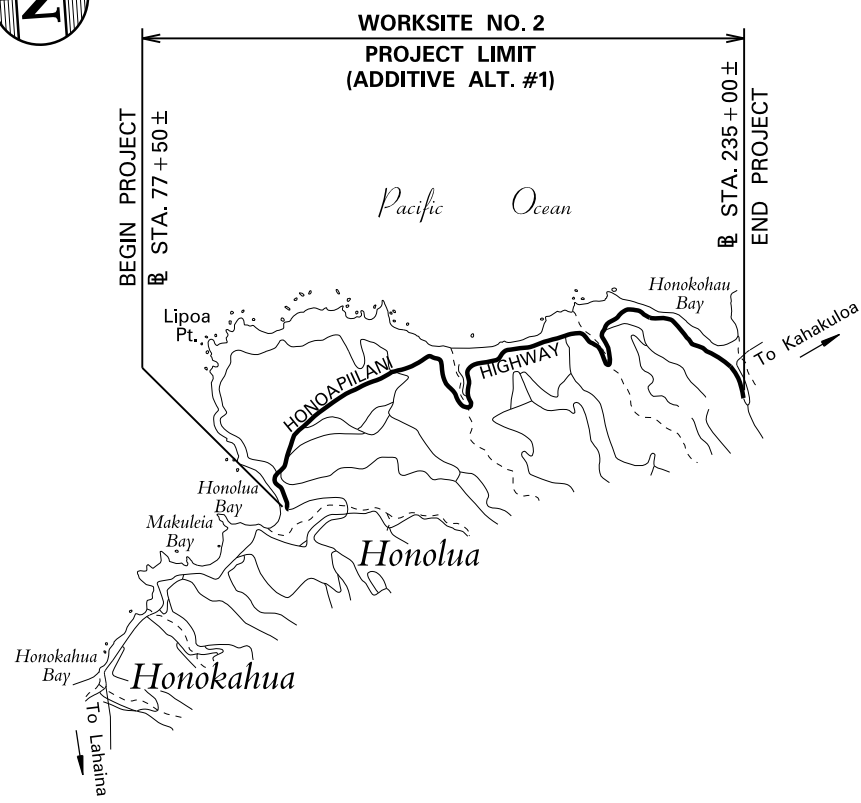
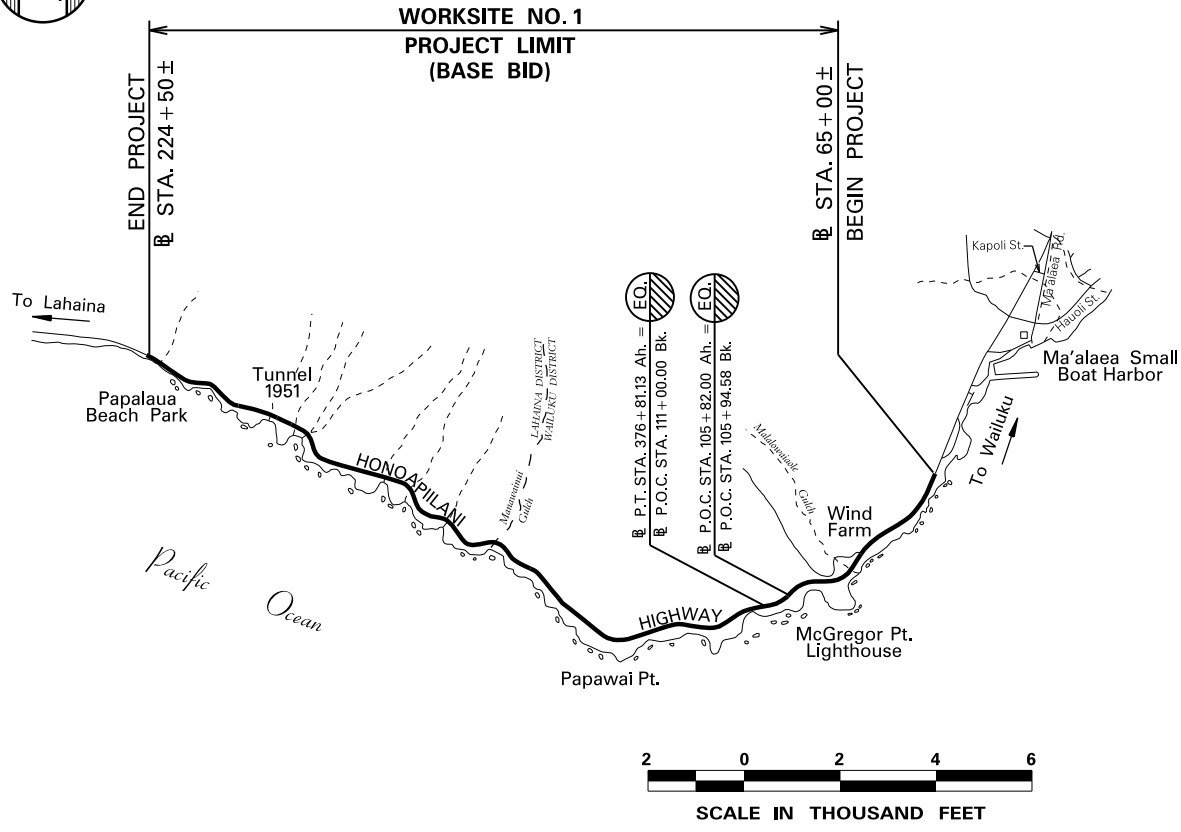
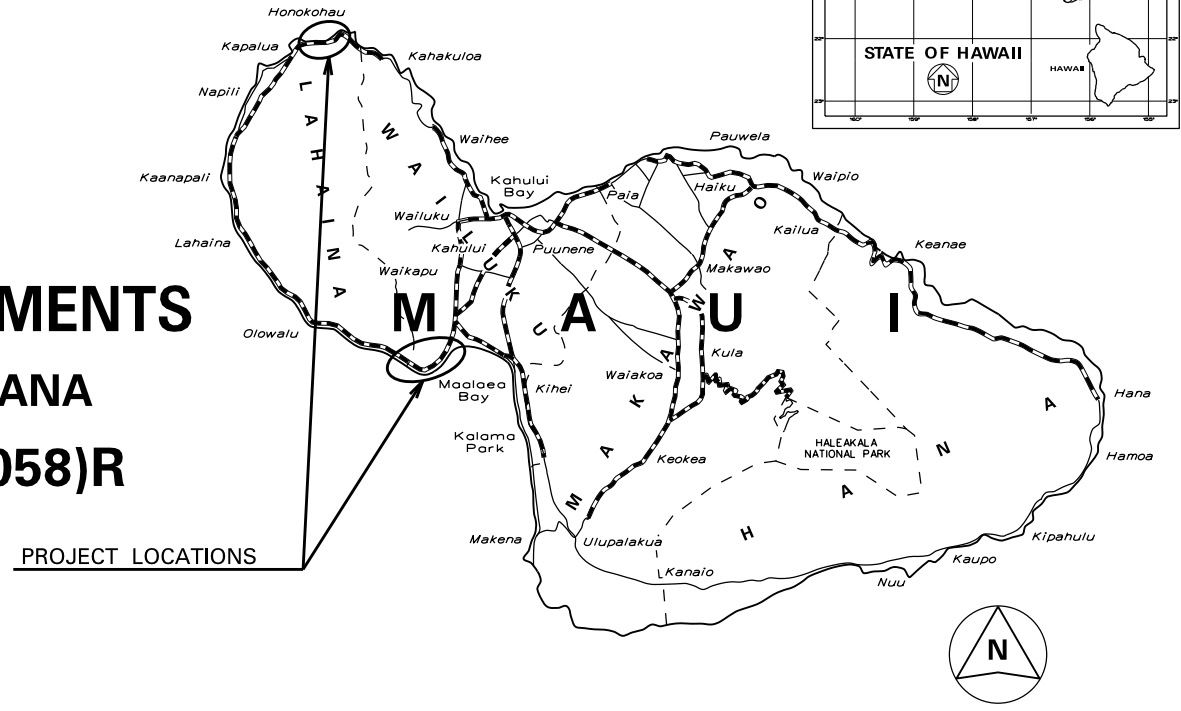
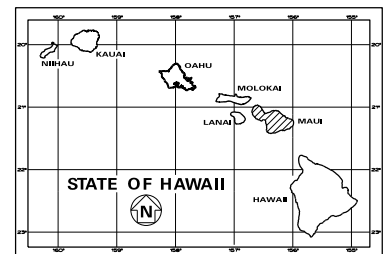

--- FEDERAL AID PROJECTS PREVIOUSLY CONSTRUCTED OR UNDER CONSTRUCTION

SOUTH OF OLOWALU MILE POST 7.25 TO MILE POST 11.00
NORTH OF KAPALUA MILE POST 33.13 TO MILE POST 36.23

DESIGN DESIGNATION		
Honoapiilani Hwy. - Route 30		
	MP 7.25-11.00	MP 33.13-36.23
TRAFFIC DATA	Kaohe Rd. to Ke Ala O Keawe Rd.	Ke Ala O Keawe Rd. to Kahekili Hwy.
ADT (2021)	32,200	5,000
ADT (2031)	36,800	5,700
DHV (2031)	2,940	570
DESIGN K	8.0	10.0
DESIGN D	55/45	55/45
DESIGN T	4.0	4.5
T24	5.0	4.5

LAYOUT PLAN
GROSS LENGTH OF PROJECT..... 6.85± MILES
NET LENGTH OF PROJECT..... 5.19± MILES

DEPARTMENT OF TRANSPORTATION
STATE OF HAWAII
APPROVED: _____ Mar 15, 2023
DIR. OF TRANSPORTATION DATE

HWY-M DESIGNED BY
HWY-M MANAGED BY
873-3535 PHONE
MAR. 2023 DATE

STANDARD PLANS SUMMARY

FED. ROAD DIST. NO.	STATE	FED. AID PROJ. NO.	FISCAL YEAR	SHEET NO.	TOTAL SHEETS
HAWAII	HAW.	STP-030-1(058)R	2023	2	40

STANDARD PLAN NO.	TITLE	DATE
B-01	NOTES & MISCELLANEOUS DETAILS	05/31/07
B-03	BACKFILL DETAILS AT EARTH RETAINING STRUCTURES	05/31/07
B-12	PRESTRESSED CONCRETE PILES & COMPRESSION SPLICE CAN DETAILS	05/31/07
B-12A	PRESTRESSED CONCRETE PILES, PILE & COMPRESSION SPLICE CAN DETAILS & NOTES	05/31/07
B-12B	PILE INTERACTION DIAGRAM	05/31/07
B-13	PRESTRESSED CONCRETE PILE BUILD-UP DETAILS	05/31/07

D-01	CATTLE GATE	05/31/07
D-02	CHAIN LINK FENCE WITH TOPRAIL	05/31/07
D-03	CHAIN LINK FENCE WITHOUT TOPRAIL	05/31/07
D-04	WIRE FENCE WITH METAL POSTS	05/31/07
D-05	TYPICAL DETAILS OF CURBS AND/OR GUTTERS	05/31/07
D-06	TYPICAL DETAIL OF REINFORCED CONCRETE DROP DRIVEWAY	05/31/07
D-07	CENTERLINE AND REFERENCE SURVEY MONUMENTS	05/31/07
D-08	STREET SURVEY MONUMENT	05/31/07
D-15	CONCRETE SIDEWALK	05/31/07
D-16	P.C.C. BUS PAD	05/31/07
D-17	P.C.C. BUS PAD	05/31/07
D-18	P.C.C. PAVEMENT LAYOUT	05/31/07
D-19	P.C.C. PAVEMENT W/ PERMEABLE BASE JOINT DETAILS	05/31/07
D-20	P.C.C. PAVEMENT W/ PERMEABLE BASE JOINT DETAILS	05/31/07
D-21	P.C.C. LONGITUDINAL JOINT DETAILS	05/31/07
D-22	P.C.C. CONNECTION TO CURBS AND GUTTERS	05/31/07
D-23	JOINTS	05/31/07

L-01	TREE PLANTING	08/16/06
L-02	TREE PLANTING	08/16/06
L-03	TREE TRANSPLANTING	08/16/06
L-04	PALM PLANTING	08/16/06
L-05	SHRUB PLANTING	08/16/06
L-06	LANDSCAPE DETAILS	08/16/06
L-07	LANDSCAPE DETAILS	08/16/06
L-08	LANDSCAPE DETAILS	08/16/06
L-09	LANDSCAPE DETAILS	08/16/06
L-10	LANDSCAPE DETAILS	08/16/06
L-11	PLANTING NOTES	08/16/06
L-12	IRRIGATION DETAILS	08/16/06
L-13	IRRIGATION DETAILS	08/16/06
L-14	IRRIGATION DETAILS	08/16/06
L-15	IRRIGATION DETAILS	08/16/06
L-16	IRRIGATION DETAILS	08/16/06
L-17	IRRIGATION DETAILS	08/16/06
L-18	IRRIGATION DETAILS	08/16/06
L-19	IRRIGATION DETAILS	08/16/06
L-20	IRRIGATION DETAILS	08/16/06
L-21	IRRIGATION DETAILS	08/16/06
L-22	IRRIGATION DETAILS	08/16/06
L-23	IRRIGATION DETAILS	08/16/06
L-24	IRRIGATION NOTES	08/16/06

STANDARD PLAN NO.	TITLE	DATE
H-01A	TYPE A CATCH BASIN	05/31/07
H-01B	TYPE B CATCH BASIN	05/31/07
H-01C	TYPE C CATCH BASIN	05/31/07
H-01D	TYPE D CATCH BASIN	05/31/07
H-01E	CATCH BASIN SECTIONS	05/31/07
H-02A	TYPE A1 CATCH BASIN	05/31/07
H-02B	TYPE B2 CATCH BASIN	05/31/07
H-02C	TYPE C1 CATCH BASIN	05/31/07
H-02D	TYPE D1 CATCH BASIN	05/31/07
H-02E	CATCH BASIN SECTION	05/31/07
H-03	TYPE A,B, AND C STORM DRAIN MANHOLE	05/31/07
H-04	TYPE D STORM DRAIN MANHOLE	05/31/07
H-05	TYPICAL REINFORCING DETAILS FOR DRAINAGE STRUCTURES	05/31/07
H-06	TYPICAL REINFORCING DETAILS FOR DRAINAGE STRUCTURES	05/31/07
H-07	CATCH BASIN AND MANHOLE CASTINGS	05/31/07
H-08	TYPE 1A-9 AND 1A-9P GRATED DROP INLET	05/31/07
H-09	TYPE 2A-9 AND 2A-9P GRATED DROP INLET	05/31/07
H-10	TYPE A-9 OR A-9P STEEL FRAMES	05/31/07
H-11	TYPE A-9 AND A-9P STEEL GRATES	05/31/07
H-12	TYPE 61614P AND 1211214P GRATED DROP INLET	05/31/07
H-13	TYPE 61616P AND 1211216P GRATED DROP INLET	05/31/07
H-14	TYPE 61214P GRATED DROP INLET	05/31/07
H-15	TYPE 1211214, 1211214P, 1211216, 1211216P STEEL FRAME AND GRATES	05/31/07
H-16	TYPE 61614, 61614P, 61616, 61616P STEEL FRAME AND GRATES	05/31/07
H-17	TYPE 61214 STEEL FRAMES AND GRATES	05/31/07
H-18	TYPE 61214P STEEL GRATES	05/31/07
H-19	TYPE 61614B STEEL FRAME AND GRATES	05/31/07
H-20	CEMENT RUBBLE MASONRY STRUCTURES	05/31/07
H-21	CONCRETE AND CEMENT RUBBLE MASONRY STRUCTURES	05/31/07
H-22	INLET/OUTLET STRUCTURE	05/31/07
H-23	INLET/OUTLET STRUCTURE	05/31/07
H-24	FLARED END SECTION FOR CULVERTS	05/31/07
H-25	FLARED END SECTION FOR CULVERTS	05/31/07
H-26	CONCRETE SPILLWAY INLET	05/31/07
H-27	CAP COUPLING DETAILS STANDARD JOINT	05/31/07
H-28	REINFORCED CONCRETE COLLAR & JACKET	05/31/07
H-29	UNDERDRAIN CLEANOUT STEEL FRAME AND COVER	05/31/07
H-30	UNDERDRAIN CONNECTION TO DRAINAGE STRUCTURE	05/31/07

TE-01 ●	SIGN HEIGHT AND LOCATION	07/11/08
TE-1A	SIGN INSTALLATION	07/11/08
TE-02A	GALVANIZED FLANGED CHANNEL SIGN POST MOUNTING	05/31/07
TE-02B	GALVANIZED FLANGED CHANNEL SIGN POST MOUNTING	05/31/07
TE-02C	GALVANIZED FLANGED CHANNEL SIGN POST MOUNTING	05/31/07
TE-03A	GALVANIZED SQUARE TUBE SIGN POST MOUNTING	05/31/07
TE-03B ●	GALVANIZED SQUARE TUBE SIGN POST MOUNTING	05/31/07
TE-04	REGULATORY SIGNS	07/11/08
TE-05	WARNING SIGNS	07/11/08
TE-06	MISCELLANEOUS SIGNS	07/11/08
TE-07 ●	CONSTRUCTION SIGNS	07/11/08
TE-08	MISCELLANEOUS INTERSECTION SIGNS	07/11/08

STANDARD PLAN NO.	TITLE	DATE
TE-09	BIKE ROUTE SIGN & SUPPLEMENTARY PLATES	07/11/08
TE-10	INTERSTATE ROUTE MARKER	07/11/08
TE-11	STATE ROUTE MARKER AND AUXILIARY MARKERS	07/11/08
TE-12	STATE ROUTE MARKER AND BORDER DETAIL FOR GUIDE SIGNS	07/11/08
TE-12A	ROUTE SIGN ASSEMBLIES	07/11/08
TE-13	STREET NAME SIGN ON MAST ARM	07/11/08
TE-14 ●	MISCELLANEOUS REFLECTOR MARKERS	07/11/08
TE-15 ●	OBJECT MARKERS	07/11/08
TE-16 ●	MILE POSTS	07/11/08
TE-17A	CANTILEVER OVERHEAD SIGN ELEVATION & DETAILS	05/31/07
TE-17B	CANTILEVER SIGN FRAME DETAIL AND SECTION	05/31/07
TE-17C	CANTILEVER SIGN FRAME DETAIL	05/31/07
TE-17D	CANTILEVER SIGN FRAME SECTION	05/31/07
TE-17E	CANTILEVER SIGN FRAME DETAILS	05/31/07
TE-18A	TWO POST OVERHEAD SIGN FRAME ELEVATIONS	05/31/07
TE-18B	TWO POST SIGN FRAMING PLAN SECTION	05/31/07
TE-18C	TWO POST SIGN FRAMING SECTIONS AND DETAILS	05/31/07
TE-18D	TWO POST SIGN FRAME DETAILS	05/31/07
TE-18E	TWO POST SIGN FRAME DETAILS	05/31/07
TE-19A	OVERHEAD SIGN FRAMING SCHEDULE	05/31/07
TE-19B	SIGN POST DRILLED SHAFT FOUNDATION	05/31/07
TE-19C	SPREAD FOOTING	05/31/07
TE-19D	SIGN FRAME FOUNDATION SCHEDULE	05/31/07
TE-19D.1	SIGN FRAME FOUNDATION SCHEDULE	05/31/07
TE-19D.2	SIGN FRAME FOUNDATION SCHEDULE	05/31/07
TE-19D.3	SIGN FRAME FOUNDATION SCHEDULE	05/31/07
TE-19D.4	SIGN FRAME FOUNDATION SCHEDULE	05/31/07
TE-19D.5	SIGN FRAME FOUNDATION SCHEDULE	05/31/07
TE-19E	ANCHORAGE DETAILS	05/31/07
TE-19F	ANCHORAGE DETAILS	05/31/07
TE-19G	MISCELLANEOUS SIGN FRAME DETAILS	05/31/07
TE-19H	LUMINAIRE WALKWAY SUPPORT	05/31/07
TE-19J	FIXED MESSAGE LUMINAIRE SUPPORT	05/31/07
TE-19K	MISCELLANEOUS SIGN DETAILS	05/31/07
TE-19L	MISCELLANEOUS SIGN DETAILS	05/31/07
TE-19M	MISCELLANEOUS SIGN FRAME DETAILS	05/31/07
TE-20	SUPPORTS FOR GROUND MOUNTED GUIDE SIGN	05/31/07
TE-20A	SUPPORTS FOR GROUND MOUNTED GUIDE SIGN	05/31/07
TE-20B	SUPPORTS FOR GROUND MOUNTED GUIDE SIGN	05/31/07
TE-20C	SUPPORTS FOR GROUND MOUNTED GUIDE SIGN	05/31/07
TE-21A	SIGN BREAKAWAY MOUNTS	05/31/07
TE-21B	SIGN BREAKAWAY MOUNTS	05/31/07
TE-22	LAMINATED ALUMINUM SIGN PANELS (OVERHEAD)	05/31/07
TE-23	LAMINATED ALUMINUM SIGN PANELS (GROUND MOUNTED)	07/11/08
TE-24	SOLID ALUMINUM EXTRUDED SIGN PANEL AND ACCESSORY DETAILS	05/31/07
TE-25	GUIDE SIGNS LUMINAIRE MOUNTINGS	05/31/07
TE-26	RAISED PAVEMENT MARKERS AND STRIPING	07/11/08
TE-27	RAISED PAVEMENT MARKERS AND STRIPING	07/11/08
TE-28	ENTRANCE AND EXIT PAVEMENT MARKINGS	07/11/08
TE-28A	MISCELLANEOUS PAVEMENT MARKINGS	07/11/08
TE-29	PAVEMENT ARROWS AND SYMBOLS	07/11/08
TE-30	PAVEMENT ALPHABETS, NUMBERS & SYMBOLS	07/11/08
TE-31	PAVEMENT ALPHABETS, NUMBERS & SYMBOLS	07/11/08

STANDARD PLAN NO.	TITLE	DATE
TE-32	TYPE I & II TRAFFIC SIGNAL SYSTEM MISC. DETAILS	05/31/07
TE-33	TYPE II TRAFFIC SIGNAL SYSTEM	08/16/06
TE-33A.1	TYPE II TRAFFIC SIGNAL STANDARD	05/31/07
TE-33A.2	TYPE II TRAFFIC SIGNAL STANDARD	05/31/07
TE-34	LOOP DETECTOR DETAILS	07/11/08
TE-35	LOOP DETECTORS & DUCT DETAILS	07/11/08
TE-36	TRAFFIC SIGNAL DETAILS	07/11/08
TE-37	PULLBOX & COVER DETAILS	07/11/08
TE-37A	TYPE "A" TRAFFIC PULLBOX	05/31/07
TE-37B	TYPE "A" TRAFFIC PULLBOX REINFORCING	05/31/07
TE-37C	TYPE "B" TRAFFIC PULLBOX	05/31/07
TE-37D	TYPE "B" TRAFFIC PULLBOX REINFORCING	05/31/07
TE-37E	TYPE "B" TRAFFIC PULLBOX FOUNDATION	05/31/07
TE-37F	TYPE "C" TRAFFIC PULLBOX	05/31/07
TE-37G	TYPE "C" TRAFFIC PULLBOX REINFORCING	05/31/07
TE-37H	TYPE "C" TRAFFIC PULLBOX FOUNDATION	05/31/07
TE-37J	TRAFFIC PULLBOX COVER AND DETAILS	05/31/07
TE-38	TYPE III TRAFFIC SIGNAL STANDARD	05/31/07
TE-38A.1	TYPE III TRAFFIC SIGNAL STANDARD	05/31/07
TE-38A.2	TYPE III TRAFFIC SIGNAL STANDARD	05/31/07
TE-39	METAL GUARDRAIL CONNECTION TO CONCRETE BARRIER	07/11/08
TE-40	CONCRETE BARRIER TRANSITION	05/31/07
TE-40A	CONCRETE BARRIER TRANSITION SECTIONS	05/31/07
TE-41	GUARDRAIL TYPE 6 (RIGID BARRIER)	05/19/21
TE-41A	GUARDRAIL TYPE 6 (RIGID BARRIER)	05/19/21
TE-41B	GUARDRAIL TYPE 6G (RIGID BARRIER W/GLARE SCREEN)	05/19/21
TE-41C	GUARDRAIL TYPE 6G (RIGID BARRIER W/GLARE SCREEN)	05/19/21
TE-41D	GUARDRAIL TYPE 6 & 6G (RIGID BARRIER)	05/19/21
TE-42	PORTABLE CONCRETE BARRIER	05/31/07
TE-43	PORTABLE CONCRETE BARRIER	05/31/07
TE-44	GUARDRAIL TYPE 4 MISCELLANEOUS DETAILS	07/11/08
TE-45	BARRICADES	07/11/08
TE-46	DELINEATION & PAVEMENT MARKINGS AT NARROW BRIDGES	07/11/08
TE-47	HIGHWAY LIGHT STANDARD	05/31/07

NOTE:
STANDARD PLANS APPLICABLE TO THIS PROJECT ARE INDICATED BY A " ● " NEXT TO THE STANDARD PLAN NO. (FOR EXAMPLE: D-07 ●)

STATE OF HAWAII
DEPARTMENT OF TRANSPORTATION
HIGHWAYS DIVISION

STANDARD PLANS SUMMARY

HONOAPIILANI HIGHWAY
GUARDRAIL & SHOULDER IMPROVEMENTS
Vicinity of North Kihei Road to Hononana
Federal-Aid Project No. STP-030-1(058)R

Date: March, 2023

SURVEY PLOTTED BY: _____ DATE: 3/23
 DRAWN BY: _____
 CHECKED BY: _____
 DESIGNED BY: LH
 QUANTITIES BY: _____
 ORIGINAL PLAN: _____
 NOTE BOOK: _____
 me/lay
 Checked by: _____

GENERAL NOTES

FED. ROAD DIST. NO.	STATE	FED. AID PROJ. NO.	FISCAL YEAR	SHEET NO.	TOTAL SHEETS
HAWAII	HAW.	STP-030-1(058)R	2023	3	40

- The project includes removing, and replacing and upgrading existing guardrails and end treatments to meet current standards. The installation of new guardrail sections and end treatments, and minor shoulder improvements are included at selected locations. The project improvements also include the installation of 1½ inch of Hot Mix Asphalt (HMA) pavement at guardrail front, under, behind, and beyond terminals.
- The removal of existing guardrail and end terminal treatments shall include disposal and be considered incidental to various contract items. The installation of new guardrail systems and end terminal treatments shall include guardrail sections, guardrail posts, terminal connectors, end sections, spacer blocks (Standard 8-inch), reflector markers (RM-5), and mounting hardware.
- The installation of new terminal end treatments with rubrail shall include the guardrail rubrail beyond (up to 75-feet) the end treatment average limit of payment and be considered incidental to the end treatment pay item. The installation of MFLT (TL-3) and MSKT-SP-MGS8 (TL-3) end treatments shall include a 5-foot (minimum) clear area behind the end treatment. Existing anchor blocks embedded in rock may be abandoned in place if protected by new end treatment and guardrail rubrail.
- The resetting of existing traffic signs, highway milepost markers and object markers to accommodate new guardrail and end terminal treatments shall be considered incidental to various contract items.
- The Contractor's attention is directed to the following Sections of the Standard Specifications and Special Provisions: Subsection 104.09 - Maintenance of Traffic; Subsection 104.11 - Utilities and Services; Subsection 105.09 - Coordination Between the Contractors; Subsection 107.06 - Contractor Duty Regarding Public Convenience; Subsection 107.12 - Protection of Persons and Property; and Section 645 - Work Zone Traffic Control.
- The existence and location of underground utilities, manholes, monuments and structures as shown on the plans are from the latest available data but the accuracy is not guaranteed. The encountering of other obstacles during the course of work is possible. The Contractor shall be held liable for any damages incurred to the existing facilities and/or improvements as a result of his operations.
- Contractor shall submit a Traffic Control Plan (TCP) and schedule at least 15 working days before the start of work for review and approval.
- Dressing of shoulder shall consists of clearing, grubbing, grading, reshaping, and compacting the unpaved shoulders with suitable excavated materials as shown on the plans and/or as directed by the Engineer. This work shall be considered incidental to the various contract items.
- All construction signs shall be left in place until all construction items have been completed. Contractor shall obtain prior approval from the Engineer to remove construction signs.
- All lanes shall be open to traffic during the morning peak hours from 6:00 a.m. to 8:00 a.m. during afternoon peak hours from 4:00 p.m. to 6:00 p.m. off work hours. Only one lane of highway shall be closed at any other time.

- The Contractor shall not leave more than 1½" drop-off at the edge of pavement, at the end of each work day. Whenever the Contractor leaves a 1½" drop-off, the Contractor shall install delineators and barricades along the edge of the pavement. This work, which includes furnishing, installing, cleaning, maintaining correct placement and removing when required, shall be considered incidental to various contract items.
- At the end of each day's work, the Contractor shall remove all equipment and other obstructions to permit free and safe passage of public traffic.
- The Contractor shall provide for access to and from all existing sideroads and driveways at all times.
- The Contractor shall construct shoulder and install guardrail only one side at a time.
- All new guardrail shall be paved in front, under, beyond and front of end terminals. Prior to installing HMA V, level and remove vegetation and compact existing ground. Refer to Plan Sheet 8.
- New end treatments shall be MASH compliant. Contractor will be required to submit shop drawing for approval during construction.









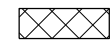

Section 7 of the Endangered Species Act:

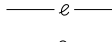
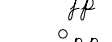
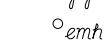
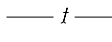
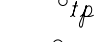
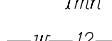
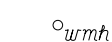
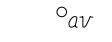
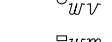
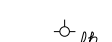
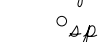
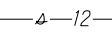
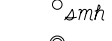
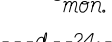
- To avoid impacts to listed Hawaiian seabirds, nighttime construction is not anticipated. If nighttime construction does occur, it shall be scheduled to avoid the seabird fledging period, September 15 through December 15. If nighttime construction occurs during other times of the year, all lighting shall be fully shielded and directed toward the ground so the bulb can only be seen from below to avoid attracting adult seabirds as they travel from the ocean to their breeding areas. Any required outdoor lighting shall have the appropriate automatic motion sensor switches and timer controls to turn off lights when there is no human activity in the vicinity. Where fences extend above vegetation, integrate durable scare tape or bird deterrent into the fence to increase visibility and minimize fence strikes.
- To avoid impacts to the Hawaiian hoary bat, no woody plants (e.g., trees and shrubs) taller than 15 feet shall be trimmed, removed, or disturbed during the hoary bat birthing and pup rearing season, June 1 through September 15.
- To avoid impacts to the Blackburn's sphinx moth, all work will occur on an existing roadway and be within the State highway right-of-way. The shoulder areas within the right-of-way are maintained on a regular basis to limit the growth of vegetation and avoid attraction of the Blackburn's sphinx moth. No critical habitat is located within the State highway right-of-way.
- To avoid impacts to the Hawaiian Stilt, no standing water will be allowed within the construction area(s) to eliminate any water resources.
- No above or below ground utilities will be moved or realigned with this project.
- No highway lighting will be installed or replaced with this project.

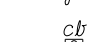
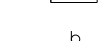
Section 106 of the National Historic Preservation Act:

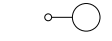
- If cultural materials are discovered during construction, all earth-moving activity within and around the immediate discovery area will be diverted until a qualified archaeologist can assess the nature and significance of the find.
- If human remains are discovered, Hawaii Administrative Rule Title 13, Chapter 300 states that further disturbances and activities shall cease in any area or nearby area suspected of overlies remains, and SHPD and the Maui Police Department will be contacted. The human remains will be treated in conformance with HAR 13-300 Subchapter 4, "Procedures for Proper Treatment of Burial Sites and Human Skeletal Remains."

LEGEND

-  Reconstruction Areas
-  Resurfacing Limits
-  Existing Electrical Pull Box
-  Existing Electrical Line
-  Existing Joint Pole
-  Existing Power Pole
-  Existing Electric Manhole
-  Existing Telephone Line
-  Existing Telephone Pole
-  Existing Telephone Manhole
-  Existing 12" Water Line
-  Existing Water Manhole
-  Existing Water Air Valve
-  Existing Water Valve Box
-  Existing Water Meter
-  Existing Fire Hydrant
-  Existing Standpipe
-  Existing 24" Drain Line
-  Existing Storm Drain Manhole
-  Existing Grated Drop Inlet
-  Existing Catch Basin
-  Existing Traffic Sign
-  New Traffic Sign
-  New Traffic Sign With 2 Posts
-  Existing Street Light
-  Existing Metal Guardrail
-  New Metal Guardrail

ORIGINAL PLAN	DATE
DESIGNED BY	3/23
NOTED BY	
QUANTITIES BY	
CHECKED BY	

STATE OF HAWAII
DEPARTMENT OF TRANSPORTATION
HIGHWAYS DIVISION

GENERAL NOTES & LEGEND

HONOAPIILANI HIGHWAY
GUARDRAIL & SHOULDER IMPROVEMENTS
Vicinity of North Kihei Road to Hononana
Federal-Aid Project No. STP-030-1(058)R

Date: March, 2023

FED. ROAD DIST. NO.	STATE	PROJ. NO.	FISCAL YEAR	SHEET NO.	TOTAL SHEETS
HAWAII	HAW.	STP-030-1(058)R	2023	4	40

NOTES FOR CONSTRUCTION WITHIN STATE RIGHT-OF-WAY

1. The Contractor shall obtain Permit to Perform Work upon State Highways from the Maui District Engineer, State Highways, at 650 Palapala Drive, prior to commencement of work within the State's highway right-of-way.
2. Removal, construction and restoration of all existing highway facilities within the State's right-of-way, including the legal relations and responsibility to the public, shall be in accordance with the current Hawaii Standard Specifications for Road and Bridge Construction, and the Specifications for Installation of Miscellaneous Improvements within State Highways, of the State Highways Division.
3. Work may not be performed between the peak hours of 6:00 a.m. to 8:30 a.m. and from 3:00 p.m. to 6:00 p.m., Monday through Friday, except State holidays, unless when otherwise approved in writing by the District Engineer.
4. During work hours, only one lane of traffic shall be closed, unless otherwise approved in writing by the District Engineer. All lane closures must be approved by HDOT fifteen (15) working days in advance. All lane closures and detours shall require advisory signs and an advertisement per section 645.03 of the Standard Specifications.
5. At certain locations, "NO LANE CLOSURE" will be allowed during the "Back To School Jam", Thanksgiving weekend, Christmas/New Year Period and at other times as directed by the Highways Division.
6. The Contractor shall provide, install, and maintain all necessary signs, lights flares, barricades, markers, cones, and other protective facilities, and shall take all necessary precautions for the protection, convenience, and safety of public traffic. All such protective facilities and precautions to be taken shall conform with the "Administrative Rules of Hawaii Governing the Use of Traffic Control Devices at Work Sites on or Adjacent to Public Streets and Highways", adopted by the Director of Transportation, and the "U.S. Federal Highway Administration MUTCD - Manual on Uniform Traffic Control Devices, Part VI - Temporary Traffic Control, 2009 Edition",
7. No material and/or equipment shall be stockpiled or otherwise stored within the highway right-of-way, except at locations designated in writing and approved by the District Engineer.
8. The Contractor shall exercise care to minimize damages to existing highway improvements. All damages shall be repaired by the Contractor, at his expense, to the satisfaction of the District Engineer.
9. All regulatory, guide, and construction signs and barricades shall have a high-intensity Type III or IV retroreflective background.
10. The Contractor shall inform the State Highway's Permit Office (873-3535) by noon Wednesday, one week prior to closing any lanes.
11. Driveways shall be kept open unless the owners of the properties using these rights-of-way are otherwise provided for satisfactorily.
12. Where pedestrian walkways exist they shall be maintained in a safe and passable conditions, or other facilities for pedestrians shall be provided. Passages between walkways at intersections shall likewise be provided. All walkways shall conform to ADA requirements.
13. The Contractor shall exercise care when performing work in or adjacent to the State highway right-of-way. Damages to the existing facilities shall be immediately reported to the respective utility companies, and/or City or State agencies. The repair work shall be done at the Contractor's expense.
14. Highway lights shall be operational during construction. Should work be necessary, the contractor shall notify the State Highways' Highway Lighting Supervisor (873-3535), three (3) working days prior to commencing work.
15. The Permit to Perform Work upon State Highways may be revoked because of default in any of the following, but not limited to, conditions:
 - a. Work performed before of after permitted hours.
 - b. Failure to maintain roadway surfaces in a smooth and safe condition.
 - c. Failure to clean up construction debris generated from project work.
 - d. Failure to provide proper traffic control.
 - e. Failure to replace damaged pavement markings and signs.
 - f. Failure to maintain highway lights and traffic signals systems.
 - g. Failure to address public complaints to the satisfaction of the District Engineer.

ORIGINAL PLAN	SURVEY PLOTTED BY	DATE
NOTE BOOK	DRAWN BY	3/23
me,lay	DESIGNED BY	
me,lay	QUANTITIES BY	
me,lay	CHECKED BY	

STATE OF HAWAII
DEPARTMENT OF TRANSPORTATION
HIGHWAYS DIVISION

GENERAL NOTES

HONOAPIILANI HIGHWAY
GUARDRAIL & SHOULDER IMPROVEMENTS
Vicinity of North Kihei Road to Hononana
Federal-Aid Project No. STP-030-1(058)R

Date: March, 2023

WATER POLLUTION AND EROSION CONTROL NOTES:

FED. ROAD DIST. NO.	STATE	FED. AID PROJ. NO.	FISCAL YEAR	SHEET NO.	TOTAL SHEETS
HAWAII	HAW.	STP-030-1(058)R	2023	5	40

A. GENERAL:

- See Special Provisions Section 209 - Water Pollution and Erosion Control. Section 209 describes but is not limited to: submittal requirements; scheduling of a water pollution and erosion control conference with the Engineer; construction requirements; method of measurement; and basis of payment. In addition, Appendix A lists potential pollutant sources and corresponding BMPs used to mitigate the pollutants.
- Follow the guidelines in the current HDOT Construction Best Management Practices Field Manual in developing, installing and maintaining the Best Management Practices (BMP) for the project. For any conflicting requirements between the Manual and applicable bid documents, the applicable bid documents will govern. Should a requirement not be clearly described within the applicable bid documents, the Contractor shall notify the Engineer immediately for interpretation. For the purposes of clarification under Note A.2, "applicable bid documents" include the construction plans, standard specifications, Special Provisions, Permits, and the Storm Water Pollution Prevention Plan (SWPPP) when applicable.
- Follow the guidelines in the Honolulu's City & County "Rules Relating to Soil Erosion Standards and Guidelines" along with applicable Soil Erosion Guidelines for projects on Maui, Molokai, Kauai, and Hawaii.
- The Engineer may assess liquidated damages of up to \$27,500 for non-compliance of each BMP requirement and each requirement stated in Section 209 and special provisions, for every day of non-compliance. There is no maximum limit on the amount assessed per day.
- The Engineer will deduct the cost from the progress payment for all citations received by the Department for non-compliance, or the Contractor shall reimburse the State for the full amount of the outstanding cost incurred by the State.
- If necessary, install a rain gage prior to any field work including the installation of any site-specific best management practices. The rain gage shall have a tolerance of at least 0.05 inches of rainfall. Install the rain gage on the project site in an area that will not deter rainfall from entering the gage opening. Do not install in a location where rain water may splash into rain gage. The rain gage installation shall be stable and plumbed. Do not begin field work until the rain gage is installed and site-specific best management practices are in-place.
- Submit Site-Specific BMP Plan to the Engineer along with a completed Site-Specific BMP Review Checklist within 30 calendar days of contract execution. The Site-Specific BMP Review Checklist may be obtained from <http://www.stormwaterhawaii.com>. Site-Specific BMP Plan shall include placing a sandbag barrier inside the culvert for temporary sediment control (refer to SC-13 in the Construction Best Management Practices Field Manual).
- The Contractor shall consider and install BMP measures which take into account high intensity and prolonged rainfall, and to address the potential problems that may result.
- All areas used in support of construction activities disturbed or damaged by the Contractor, including but not limited to, staging areas, construction entrance/exit, and travel routes, shall be temporarily stabilized during construction in accordance with Section 209 of the 2005 Standard Specifications for Road, Bridge, and Public Works Construction. These areas shall be restored to their original condition or better upon completion of construction. Disturbed and exposed areas shall be permanently stabilized using vegetative cover, pavement, or equivalent to match pre-existing or better condition as approved by the State.
- Final stabilization and restoration of disturbed or damaged areas shall begin immediately as soon as construction is completed and the construction support areas are no longer used.
- The State reserves the right to determine the appropriateness and adequacy of proposed and/or implemented BMPs. Additional BMP measures required by the State shall not be paid for by the State.
- The Contractor shall be responsible for all damages and/or injuries resulting from the BMPs.
- The Contractor shall be responsible for any citations or fines that may be levied as related to the NPDES program on this permit, whether directly levied against the Contractor or the Department of Transportation.

14. The Contractor may discuss proposed and implemented BMP measures and the adequacy of them, with District Engineer.

B. WASTE DISPOSAL:

- Waste Materials**
Collect and store all waste materials in a securely lidded metal dumpster or roll off container with cover to keep rain out or loss of waste during windy conditions. The dumpster shall meet all local and State solid waste management regulations. Deposit all trash and construction debris from the site in the dumpster. Empty the dumpster weekly or when the container is two-thirds full, whichever is sooner. Do not bury construction waste materials onsite. The Contractor's supervisory personnel shall be instructed regarding the correct procedure for waste disposal. Post notices stating these practices in the office trailer, on a weatherproof bulletin board, or other accessible location acceptable to the Engineer. The Contractor shall be responsible for seeing that these procedures are followed. Submit the Solid Waste Disclosure Form for Construction Sites to the Engineer within 30 calendar days of contract execution. Provide a copy of all the disposal receipts from the facility permitted by the Department of Health to receive solid waste to the Engineer monthly. This should also include documentation from any intermediary facility where solid waste is handled or processed.
- Hazardous Waste**
Dispose all hazardous waste materials in the manner specified by local, federal or State regulations and by the manufacturer. The Contractor's site personnel shall be instructed in these practices and shall be responsible for seeing that these practices are followed.
- Sanitary Waste**
Collect all sanitary waste from the portable units a minimum of once per week, or as required. Position sanitary facilities where they are secure and will not be tipped over or knocked down.

C. EROSION AND SEDIMENT CONTROL INSPECTION AND MAINTENANCE PRACTICES:

- For projects with an NPDES Permit for Construction Activities, inspect at the following intervals. For construction areas discharging to nutrient or sediment impaired waters, inspect all control measures at least once each week and within 24 hours of any rainfall event of 0.25 inches or greater within a 24 hour period. For construction areas discharging to waters not impaired for nutrient or sediments, inspect all control measures weekly. Inspections are only required during the project's normal working hours. The discharge point water classification may be found in the SWPPP.
- For projects without an NPDES Permit for Construction Activities, inspect all control measures weekly.
- Maintain all erosion and sediment control measures in good working order. If repair is necessary, initiate repair immediately and complete by the close of the next work day if the problem does not require significant repair or replacement, or if the problem can be corrected through routine maintenance. When installation of a new erosion or sediment control or a significant repair is needed, install the new or modified control or complete the repair no later than 7 calendar days from the time of discovery. "Immediately" means the Contractor shall take all reasonable measures to minimize or prevent discharge of pollutants until a permanent solution is installed and made operational. If a problem is identified at a time in the day in which it is too late to initiate repair, initiation of repair shall begin on the following work day.
- Remove built-up sediment from silt fence when it has reached one-third the height of the fence. Remove sediment from other perimeter sediment control devices when it has reached one-half the height of the device.
- Inspect silt screen or fence for depth of sediment, tears, to verify that the fabric is securely attached to the fence posts or concrete slab and to verify that the fence posts are firmly in the ground. Inspect and verify the bottom of the silt screen is buried a minimum of 6 inches below the existing ground.
- Inspect temporary and permanent seeding and planting for bare spots, washouts and healthy growth.
- Complete and submit to the Engineer a maintenance inspection report within 24 hours after each inspection.

ORIGINAL PLAN	DATE
DESIGNED BY	3/23
CHECKED BY	
DATE	
DESIGNED BY	
CHECKED BY	
DATE	
DESIGNED BY	
CHECKED BY	
DATE	

STATE OF HAWAII
DEPARTMENT OF TRANSPORTATION
HIGHWAYS DIVISION

WATER POLLUTION & EROSION CONTROL NOTES

HONOAPIILANI HIGHWAY
GUARDRAIL & SHOULDER IMPROVEMENTS
Vicinity of North Kihei Road to Hononana
Federal-Aid Project No. STP-030-1(058)R

Date: March, 2023

WATER POLLUTION AND EROSION CONTROL NOTES (Cont.):

FED. ROAD DIST. NO.	STATE	FED. AID PROJ. NO.	FISCAL YEAR	SHEET NO.	TOTAL SHEETS
HAWAII	HAW.	STP-030-1(058)R	2023	6	40

8. Provide a stabilized construction entrance at all points of exit onto paved roads to reduce vehicle tracking of sediments. Include stabilized construction entrance in the Water Pollution, Dust, and Erosion Control submittals. Minimum length should be 50 feet. Minimum width should be 30 feet. Minimum depth should be 12 inches or as recommended by the soils engineer and underlain with geo-textile fabric. If minimum dimensions cannot be met, provide other stabilization techniques that remove sediment prior to exit. Clean the paved street adjacent to the site entrance daily or as required to remove any excess mud, cold-planed materials, dirt or rock tracked from the site. Do not hose down the street without containing or vacuuming wash water. Cover dump trucks hauling material from the construction site with a tarpaulin. Remove sediment tracked onto the street, sidewalk, or other paved area by the end of the day in which the track-out occurs.
9. Include designated Concrete Washout Area(s) in the Water Pollution, Dust, and Erosion Control submittals.
10. Submit the name of a specific individual designated responsible for inspections, maintenance and repair activities and filling out the inspection and maintenance report.
11. Personnel selected for the inspection and maintenance responsibilities shall receive training from the Contractor. They shall be trained in all the inspection and maintenance practices necessary for keeping the erosion and sediment controls used onsite in good working order.
12. Contain, remove, and dispose slurry generated from saw cutting of pavement in accordance with approved BMP practices. Do not allow discharge into the drainage system or State waters.
13. For projects with an NPDES Permit for Construction Activities, immediately initiate stabilizing exposed soil areas upon completion of earth-disturbing activities for areas where earth-disturbing activities have permanently or temporarily ceased. Earth-disturbing activities have permanently ceased when clearing and excavation within any area of the construction site that will not include permanent structures has been completed. Earth-disturbing activities have temporarily ceased when clearing, grading, and excavation within any area of the site that will not include permanent structures will not resume (i.e., the land will be idle) for a period of 14 or more calendar days, but such activities will resume in the future. For construction areas discharging into waters not impaired for nutrients or sediments, complete initial stabilization within 14 calendar days after the temporary or permanent cessation of earth-disturbing activities. For construction areas discharging into nutrient or sediment impaired waters, complete initial stabilization within 7 calendar days after the temporary or permanent cessation of earth-disturbing activities. Classification of water at the discharge point may be found in the SWPPP.
14. For projects without an NPDES Permit for Construction Activities, complete initial stabilization within 14 calendar days after the temporary or permanent cessation of earth-disturbing activities.

D. GOOD HOUSEKEEPING BEST MANAGEMENT PRACTICES:

1. Materials Pollution Prevention Plan

- a. Applicable materials or substances listed below are expected to be present onsite during construction. Other materials and substances not listed below shall be added to the inventory.

Concrete	Cleaning Solvents
Detergents	Wood
Paints (enamel and latex)	Masonry Block
Metal Studs	Herbicides and Pesticides
Tar	Curing Compounds
Fertilizers	Adhesives
Petroleum Based Products	

- b. Use Material Management Practices to reduce the risk of spills or other accidental exposure of materials and substances to storm water runoff. Make an effort to store only enough product as is required to do the job.
- c. Store all materials stored onsite in a neat, orderly manner in their appropriate containers and if possible under a roof or other enclosure.

- d. Keep products in their original containers with the original manufacturer's label.
 - e. Do not mix substances with one another unless recommended by the manufacturer.
 - f. Whenever possible, use a product up completely before disposing of the container.
 - g. Follow manufacturer's recommendations for proper use and disposal.
 - h. Conduct a daily inspection to ensure proper use and disposal of materials onsite.
2. Hazardous Material Pollution Prevention Plan
 - a. Keep products in original containers unless they are not resealable.
 - b. Retain original labels and Safety Data Sheets (SDS), formerly Material Safety Data Sheets (MSDS).
 - c. Dispose of surplus products according to manufacturers' instructions and local and State or Federal regulations.
 3. Onsite and Offsite Product Specific Plan

The following product specific practices shall be followed onsite:

 - a. Petroleum Based Products:

Monitor all onsite vehicles for leaks and perform regular preventive maintenance to reduce the chance of leakage. Store petroleum products in tightly sealed containers which are clearly labeled. Apply asphalt substances used onsite according to the manufacturer's recommendation.
 - b. Fertilizers:

Apply fertilizers used only in the minimum amounts recommended by the manufacturer and federal, state, and local requirements. Avoid applying just before a heavy rain event. Apply at the appropriate time of year for the location, and preferably timed to coincide as closely as possible to the period of maximum vegetation uptake and growth. Once applied, work fertilizer into the soil to limit exposure to storm water. Do not apply to storm conveyance channels with flowing water. Storage shall be in a covered shed or in an area where fertilizer will not come into contact with precipitation or stormwater. Transfer the contents of any partially used bags of fertilizer to a sealable plastic bin to avoid spills.
 - c. Paints:

Seal and store all containers when not required for use. Do not discharge excess paint to the drainage system, sanitary sewer system, or State waters. Dispose properly according to manufacturers' instructions and State and local regulations.
 - d. Concrete Trucks:

Washout or discharge concrete truck drum wash water only at a designated site as far as practicable from storm drain inlets or State waters. Do not discharge water in the drainage system or State waters. Disposal by percolation is prohibited. Clean disposal site as required or as requested by the Engineer.
 4. Spill Control Plan
 - a. Post a spill prevention plan to include measures to prevent and clean up each spill.
 - b. The Contractor shall be the spill prevention and cleanup coordinator. Designate at least three site personnel who shall receive spill prevention and cleanup training. These individuals shall each become responsible for a particular phase of prevention and cleanup. Post the names of responsible spill personnel in the material storage area on a weatherproof bulletin board or other accessible location acceptable to the Engineer and in the office trailer onsite.
 - c. Clearly post manufacturers' recommended methods for spill cleanup. Make site personnel aware of the procedures and the location of the information and cleanup supplies.
 - d. Keep ample materials and equipment necessary for spill cleanup in the material storage area onsite.
 - e. Clean up all spills immediately after discovery.
 - f. Keep the spill area well ventilated. Personnel shall wear appropriate protective clothing to prevent injury from contact with a hazardous substance.

DATE	3/23
SURVEY PLOTTED BY	
DRAWN BY	
DESIGNED BY	LH
QUANTITIES BY	
CHECKED BY	
ORIGINAL PLAN	
NOTE BOOK	
DATE	
NO.	

STATE OF HAWAII
DEPARTMENT OF TRANSPORTATION
HIGHWAYS DIVISION

WATER POLLUTION & EROSION CONTROL NOTES

HONOAPIILANI HIGHWAY
GUARDRAIL & SHOULDER IMPROVEMENTS
Vicinity of North Kihei Road to Hononana
Federal-Aid Project No. STP-030-1(058)R

Date: March, 2023

FED. ROAD DIST. NO.	STATE	FED. AID PROJ. NO.	FISCAL YEAR	SHEET NO.	TOTAL SHEETS
HAWAII	HAW.	STP-030-1(058)R	2023	7	40

g. Where a leak, spill, or other release containing a hazardous substance or oil in an amount equal to or in excess of a reportable quantity established under either 40 CFR Part 110, 40 CFR Part 117, or 40 CFR Part 302 occurs during a 24-hour period, the Contractor shall notify the Engineer as soon as the Contractor has knowledge of the discharge. Note that the reportable quantity for oil and fuel products is a spill of 25 gallons or more, a spill not cleaned within 72 hours, or a spill that threatens ground or surface waters. The Engineer will notify the National Response Center (NRC) at (800) 424-8802, the Clean Water Branch during regular business hours at 586-4309, the Clean Water Branch (DOH-CWB) via email at cleanwaterbranch@doh.hawaii.gov during non-business hours, the DOH Hazard Evaluation and Emergency Response Office at (808) 586-4249, the Coast Guard Maui Station at (808) 986-0023 and the local Emergency Planning Committee at (808) 720-7285. The Contractor shall also provide to the Engineer, within 1 calendar days of knowledge of the release, a description of the release, the circumstances leading to the release, and the date of the release. The Engineer will provide this information to the DOH-CWB. The Engineer will provide information to the NRC if requested.

E. PERMIT REQUIREMENTS:

1. The calculated land disturbance area for this project based on the construction plans is 0.15 acres not including Contractor Staging and Storage areas. If the total of the disturbed area and the Contractor Staging and Storage area is one acre or greater, the Contractor shall obtain the NPDES Construction Activities Permit using HDOT's latest SWPPP template. See Hawaii Administrative Rules Chapter 11-55, Appendix C for the definition of land disturbance. The Contractor shall be responsible for obtaining the required NPDES Construction Activities Permit and complying with the requirements of HAR 11-55 including, but not limited to:
 - a. Deadlines for initiating and completing initial stabilization
 - b. Increased inspection frequency and installation of rain gage if applicable
 - c. Deadlines to initiate and complete repairs to BMPs
 - d. Reporting requirements and corrective action reports
2. Comply with all applicable State and Federal Permit conditions. Permits may include, but not limited to the following:
 - a. NPDES Permit for Construction Activities
 - b. NPDES Permit for Construction Dewatering
 - c. NPDES Permit for Hydrotesting Waters
 - d. Water Quality Certification
 - e. Stream Channel Alteration Permit
 - f. Section 404 Army Corps of Engineer Permit

F. SITE-SPECIFIC BMP REQUIREMENTS:

Each BMP below is referenced to the corresponding section of the current HDOT Construction Best Management Practices Field Manual and appropriate Supplemental Sheets. The Manual may be obtained from the HDOT Statewide Stormwater Management Program Website at <http://www.stormwaterhawaii.com/resources> under Construction Best Management Practices Field Manual. Supplemental BMP sheets are located at http://stormwaterhawaii.com/contractors/contractors_BMPmanual.aspx under Concrete Curing and Irrigation Water.

The requirements for Water Pollution, Dust, and Erosion Control submittals are included in Section 209 of the Hawaii Standard Specifications for Road and Bridge Construction dated 2005 and applicable Special Provisions. A list of pollutant sources and corresponding BMP used to mitigate the pollutants are included in Section 209 of the Special Provisions under Appendix A.

Follow the requirements below:

1. Protect all Drainage Inlets receiving runoff from disturbed areas (SC-1).
2. Contain on-site runoff using Perimeter Sediment Controls
 - a. SC-7 Silt Fence or Filter Fabric Fence
 - b. SC-2 Vegetated Filter Strips and Buffers
 - c. SC-6 Compost Filter Berm/Sock
 - d. SC-8 Sandbag Barrier
 - e. SC-9 Brush or Rock Filter
3. Control offsite runoff from entering construction area
 - a. EC-3 Run-On Diversion
 - b. EC-5 Earth Dikes, Swales, and Ditches
4. Incorporate applicable Site Management BMP
 - a. SM-1 Construction BMP Training
 - b. SM-2 Material Storage and Handling
 - c. SM-3 Stockpile Management
 - d. SM-6 Solid Waste Management
 - e. SM-7 Sanitary Waste Management
 - f. SM-9 Hazardous Materials and Management
 - g. SM-10 Spill Prevention and Control
 - h. SM-11 Vehicle and Equipment Cleaning
 - i. SM-12 Vehicle and Equipment Maintenance
 - j. SM-13 Vehicle and Equipment Refueling
 - k. SM-14 Scheduling
 - l. SM-15 Location of Potential Sources of Sediment
 - m. SM-16 Staging Area
 - n. SM-17 Preservation of Existing Vegetation
 - o. SM-19 Dust Control
 - p. SM-20 Paving Operations
 - q. SM-21 Structure Construction and Painting
5. Contain pollutants within the Construction Staging/Storage Area BMP with applicable Perimeter Sediment Controls and Site Management BMP. Include a Stabilized Construction Entrance/Exit (SC-11) for all areas which exit onto a paved street. Restrict vehicle access to these points.
6. Manage Concrete Waste including installing a Concrete Washout Area (SM-4) and properly disposing of Concrete Curing Water (California Stormwater BMP Handbook NS-12 Concrete Curing).
7. Remove saw cut slurry and hydrodemolition water from the site by vacuuming. Provide storm drain protection and/or perimeter sediment controls during saw cutting and hydrodemolition work.

ORIGINAL PLAN	DATE
DESIGNED BY	3/23
CHECKED BY	
NOTED BY	
QUANTITIES BY	
CHECKED BY	

STATE OF HAWAII
DEPARTMENT OF TRANSPORTATION
HIGHWAYS DIVISION

WATER POLLUTION & EROSION CONTROL NOTES

HONOAPIILANI HIGHWAY
GUARDRAIL & SHOULDER IMPROVEMENTS
Vicinity of North Kihei Road to Hononana
Federal-Aid Project No. STP-030-1(058)R

Date: March, 2023

FED. ROAD DIST. NO.	STATE	FED. AID PROJ. NO.	FISCAL YEAR	SHEET NO.	TOTAL SHEETS
HAWAII	HAW.	STP-030-1(058)R	2023	8	40

EROSION CONTROL/BEST MANAGEMENT PRACTICES NOTES

1. The Contractor, at his own expense, shall keep the project areas and surrounding areas free from dust nuisance. The work shall be done in conformance with air pollution control standards contained in Hawaii Administrative Rules: Chapter 11-60, "Air Pollution Control".
2. Measures to control erosion and other pollutants shall be in place before any grading work is initiated. These measures shall be properly constructed and maintained throughout the construction period of each site.
3. Construction shall be sequenced to avoid disturbance at all project sites at one time and minimize exposure time of the demolition and reconstruction areas.
4. The Contractor shall observe and comply with the State Department of Health regulations regarding storm water discharge.
5. Inlet protection shall be implemented at all storm drain inlets and catch basins as indicated to prevent any sediment laden runoff from leaving the site. Inlet protection devices shall be removed during any event where flooding could occur if devices remain in place and replaced after the event has passed.
6. Good housekeeping shall be utilized to ensure protection of roadways from mud, dirt, and debris.
7. The Contractor shall provide erosion control measures for their construction, staging, and storage areas and shall inspect and monitor his construction, staging, and storage areas to ensure that no non-storm water discharges are emitted. If such sources are identified the Contractor shall provide immediate mitigative measures.
8. No sediment laden runoff shall leave the site
9. Water trucks shall be utilized to minimize the amount of airborne dust.
10. Contractor shall ensure the proper working order and conduct regular maintenance of all construction equipment. All construction equipment shall be serviced off-site, and no oil or fuel shall be stored on the site.
11. The Contractor shall dispose of equipment and hydraulic oils off-site and in accordance with County, State, and Federal regulations.
12. At the end of the construction, existing catch basins and drain Inlets surrounding the project site shall be inspected and any accumulated sediment and debris found shall be removed. Flushing into the catch basins or drain inlets is prohibited.
13. Construction shall be staged and phased for large projects. Areas of one phase shall be stabilized before another phase is initiated. Stabilization shall be accomplished by temporary or permanent protecting the disturbed soil surface from rainfall impacts and runoff.
14. Storm water flowing toward the construction area shall be diverted by using appropriate control measures, as practical.
15. Water must be discharged in a manner that the discharge shall not cause or contribute to a violation of the basic water quality criteria as specified in the Hawaii Administrative Rules, Section 11-54-04.
16. All grading work shall conform to Maui County Code chapter 20.08 "Soil Erosion and Sediment Control", as amended and applicable provisions of Chapter 54, Water Quality Standards and Chapter 55, Water Pollution Control, Title II, Administrative Rules of the State Department of Health.
17. The Contractor shall schedule construction during the dry weather periods and shall be prepared in case of rainfall events. The Contractor shall provide for temporary bypass or detention of storm water flows or other measures to avoid flooding of properties upstream or adjacent to the site.

ORIGINAL PLAN	DATE
SURVEY PLOTTED BY	3/23
DRAWN BY	
DESIGNED BY	
NOTE BOOK	
QUANTITIES BY	
CHECKED BY	

STATE OF HAWAII
DEPARTMENT OF TRANSPORTATION
HIGHWAYS DIVISION

WATER POLLUTION & EROSION CONTROL NOTES

HONOAPIILANI HIGHWAY
GUARDRAIL & SHOULDER IMPROVEMENTS
Vicinity of North Kihei Road to Hononana
Federal-Aid Project No. STP-030-1(058)R

Date: March, 2023

GENERAL NOTES

- All hardware, posts and fasteners shall be hot-dip zinc coated galvanized after fabrication. No punching, drilling or cutting will be permitted after galvanizing.
- Where conditions require, special post lengths in increments of 6 inches may be specified by the Engineer.
- All fasteners, posts, and rail elements (i.e. FBB03, PWE01, RWM04b, etc.) shall conform to the latest edition and amendments of "A Guide to Standardized Highway Barrier Rail Hardware", a report prepared and approved by the AASHTO-AGC-ARTBA Joint Cooperative Committee, Subcommittee On New Highway Materials, Task Force 13 Report. Dimensions of fasteners, posts and rail elements have been converted from metric units into their present form.
- The Blockout or Offset Block shall be approved by the State.
- All new guardrail systems (system consists of total length of guardrail including both end treatments) shall include the Additional Paved Area.
- After the guardrail posts are installed in the paved area, the Contractor shall fill/seal around each guardrail post and all cracks in the paved area caused during the guardrail post installation. If required by the inspector/engineer, the Contractor shall tamper the paved area around the guardrail post prior to filling/sealing. All costs associated with this work shall not be paid for separately, but shall be considered incidental to the various guardrail items.
- When standards for the fill slope area cannot be met, a site specific, engineer approved design may be used.
- Minimum working width (clear distance) between back of MGS post to any fixed object is 4'-1" (49").
- New Hot Mix Asphalt (HMA) pavement at guardrails shall extend 6 feet longitudinally beyond terminal ends.
- Reflector Markers (RM-5) mounted on guardrails shall be spaced every 25 feet. RM-5's shall not be installed on Terminal Sections. Furnishing and installing of each RM-5 shall be considered incidental to the guardrail system.

GUARDRAIL TYPE	DIMENSION	
	H	A
MGS w/ Standard 8" Offset Block	2'-1"	1'-6"
MGS w/ No Blockout	2'-7/8"	9/4"

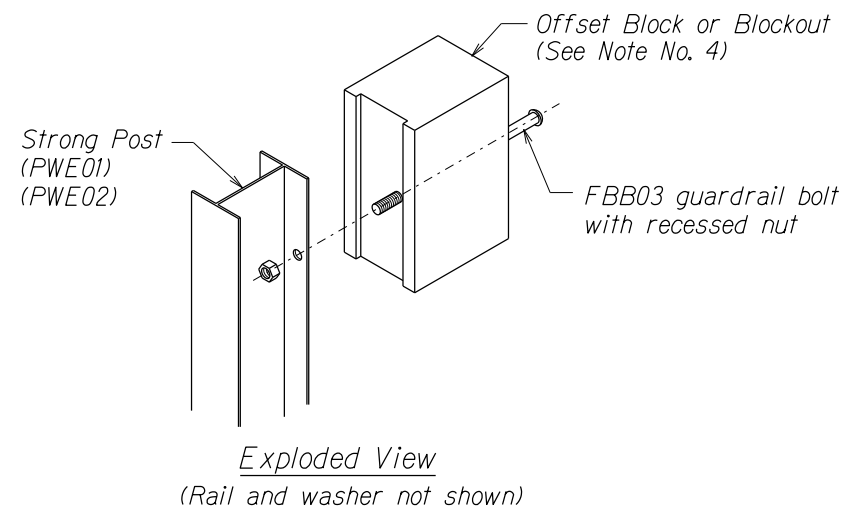

STEEL POST AND BLOCK DETAIL

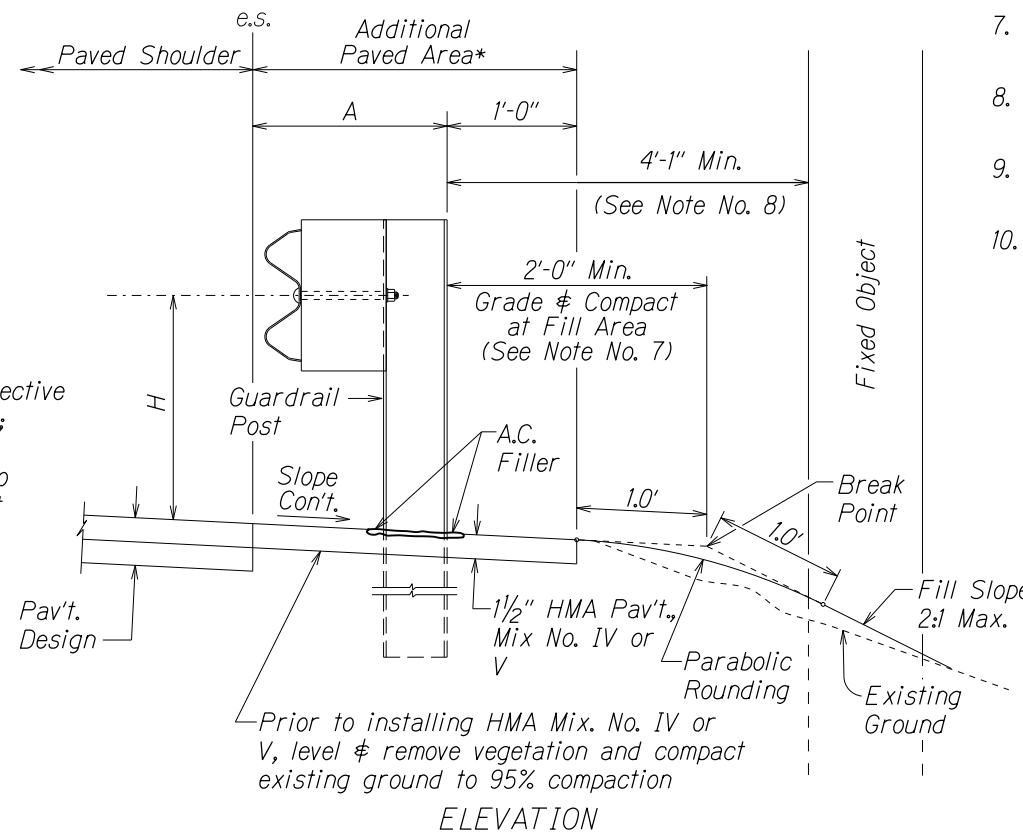
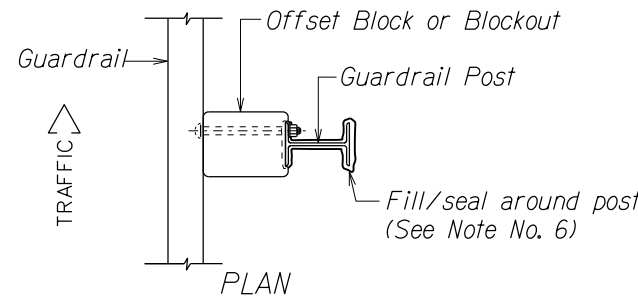

TYPICAL GUARDRAIL INSTALLATION

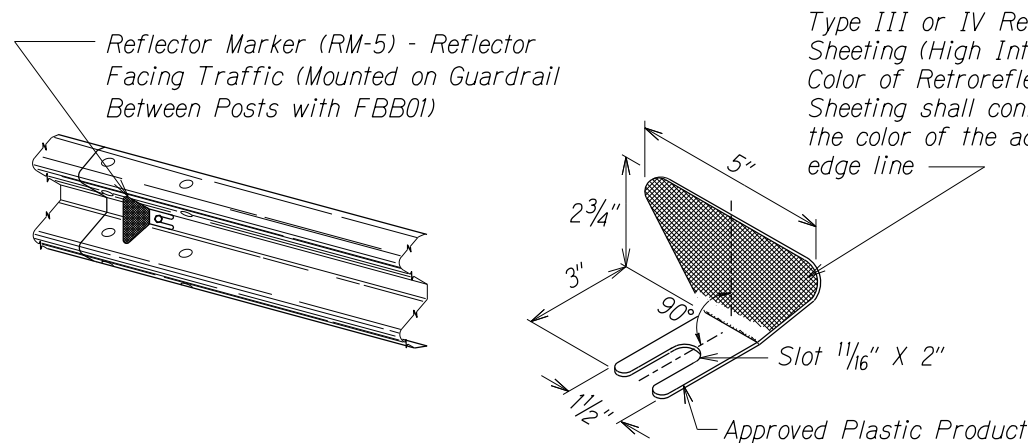

REFLECTOR MARKER (RM-5) DETAIL AND TYPICAL INSTALLATION



STATE OF HAWAII
DEPARTMENT OF TRANSPORTATION
HIGHWAYS DIVISION

GUARDRAIL DETAILS & NOTES
HONOAPIILANI HIGHWAY
GUARDRAIL & SHOULDER IMPROVEMENTS
Vicinity of North Kihei Road to Hononana
Federal-Aid Project No. STP-030-1(058)R

Scale: NTS Date: March, 2023

SHEET No. 1 OF 12 SHEETS

SURVEY PLOTTED BY: DATE: 3/23
DRAWN BY: LH
DESIGNED BY: LH
QUANTITIES BY: LH
CHECKED BY: LH
ORIGINAL PLAN No.
NOTE BOOK No.

r05/03/18 D:\s2\Ernest\standards\Traffic Guardrail Standards\archive\ml_1e50rev.dgn

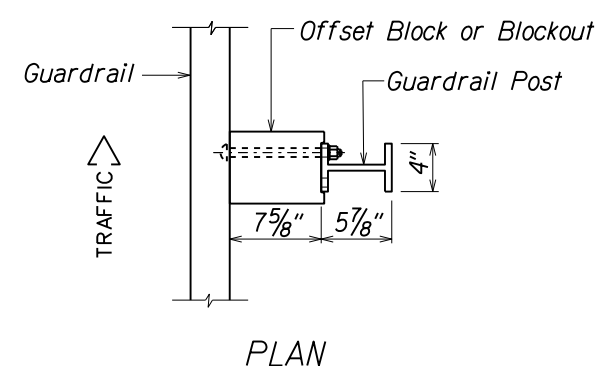

NOTE:
All Holes are
3/4" Dia.

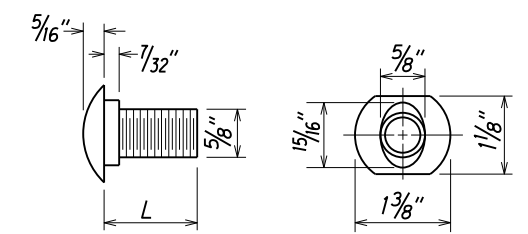
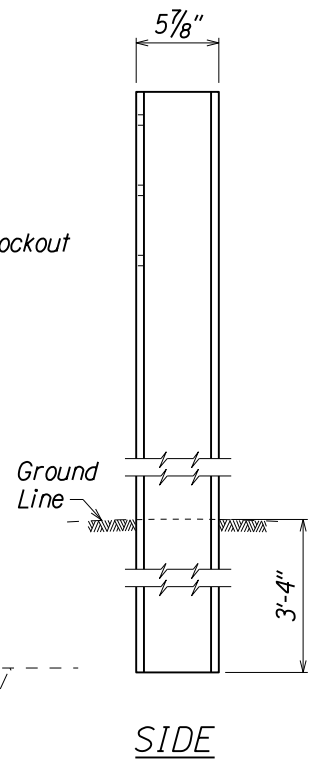
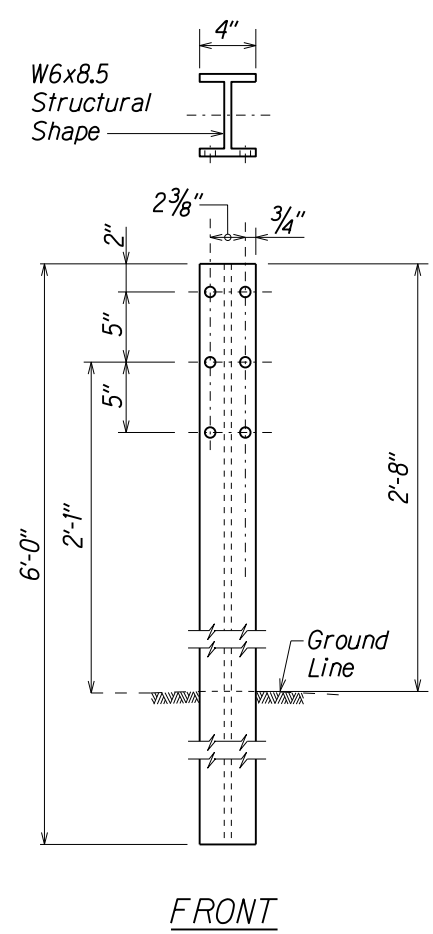

DESIGNATOR	L
FBB01	1 3/8"
FBB02	2"
FBB03	10"

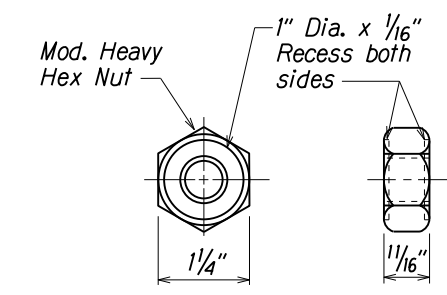

GUARDRAIL BOLTS AND RECESSED NUT

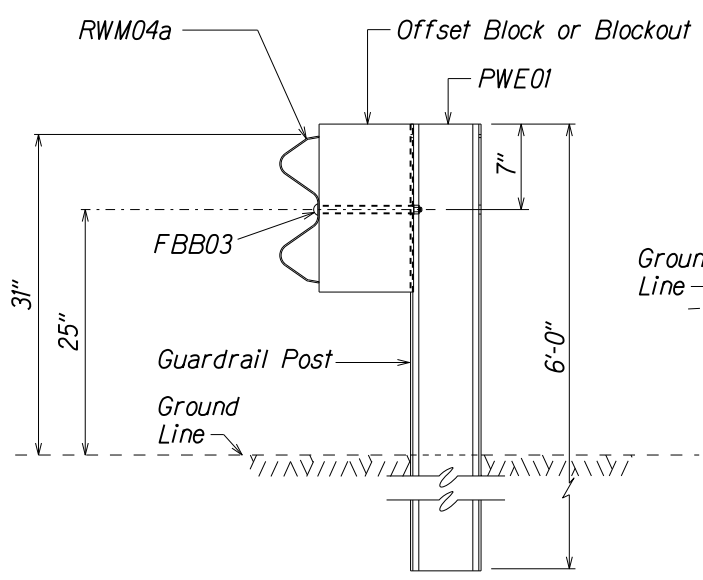

SECTION A-A

WIDE-FLANGED GUARDRAIL POST (PWE01)

DESIGNATOR	BASE METAL THICKNESS
RWM04a	12 Gauge

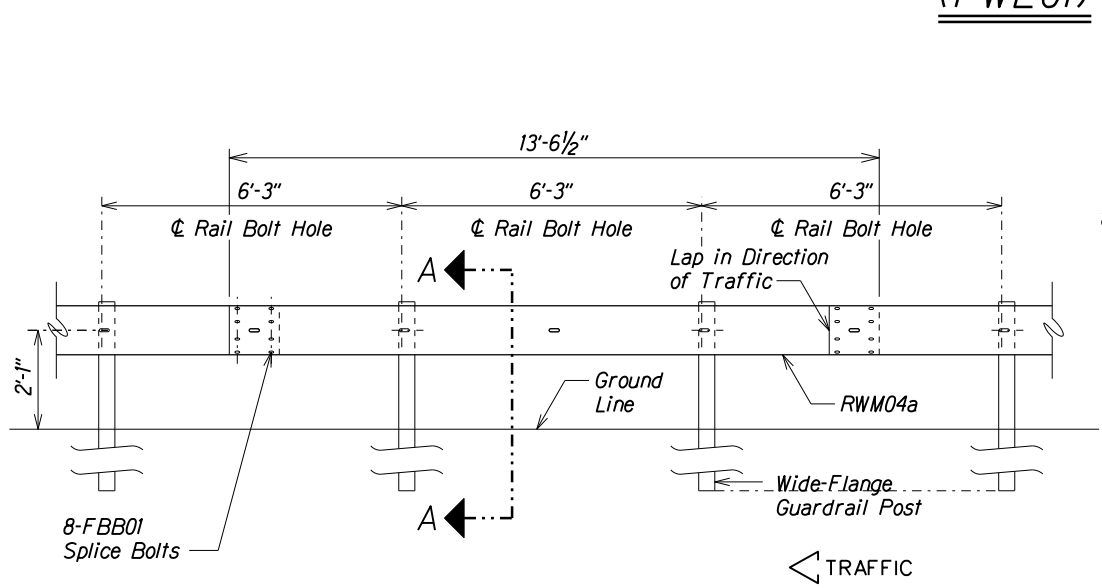
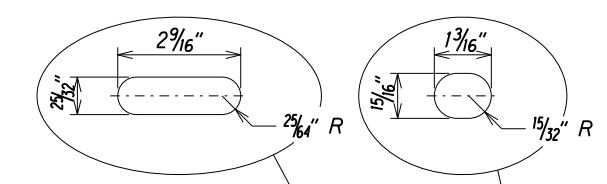

ELEVATION

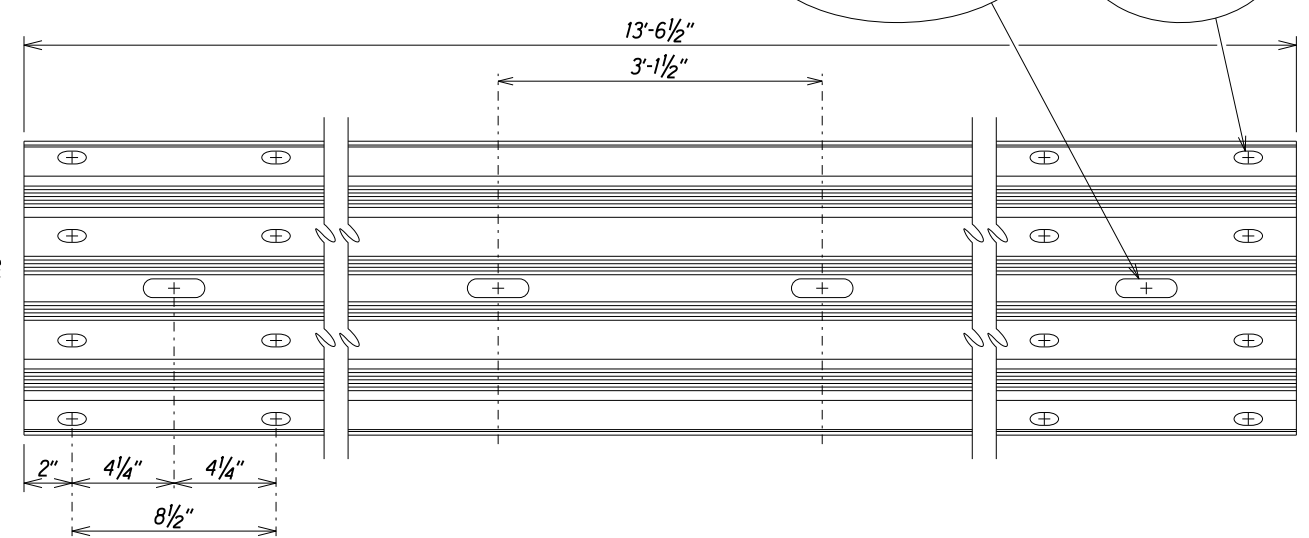
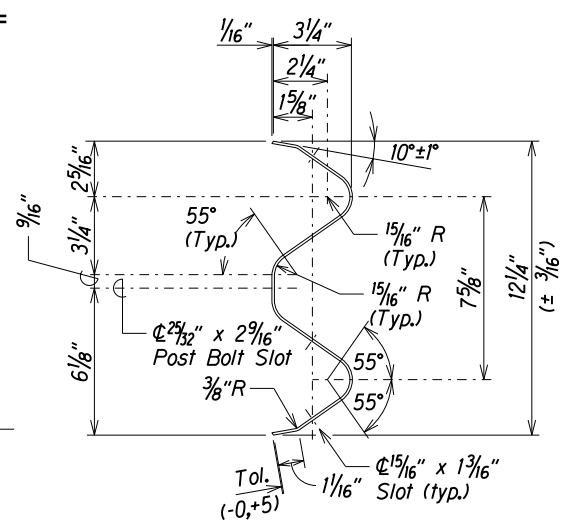

4 SPACE W-BEAM GUARDRAIL (RWM04a)

MIDWEST GUARDRAIL SYSTEM WITH STANDARD 8" OFFSET BLOCK (SGR47)



STATE OF HAWAII
DEPARTMENT OF TRANSPORTATION
HIGHWAYS DIVISION
3" W-BEAM GUARDRAIL WITH STANDARD 8" OFFSET BLOCK
HONOAPILANI HIGHWAY GUARDRAIL & SHOULDER IMPROVEMENTS
Vicinity of North Kihei Road to Hononana
Federal-Aid Project No. STP-030-1(058)R
Scale: NTS Date: March, 2023
SHEET No. 2 OF 12 SHEETS

SURVEY PLOTTED BY: DATE: 3/23
DRAWN BY: LH
DESIGNED BY: LH
QUANTITIES BY:
CHECKED BY:
ORIGINAL PLAN No.
NOTE BOOK No.

r02/05/20 D:\usr2\Ernest\standards\Traffic\Guardrail Standards\archive\m2_wbeamsp.dgn

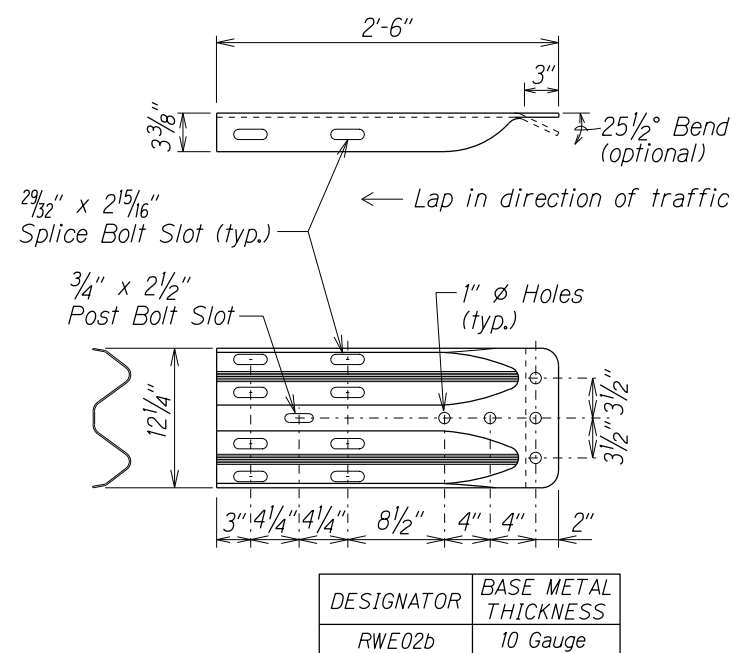

DESIGNATOR	BASE METAL THICKNESS
RWE02b	10 Gauge

W-BEAM TERMINAL CONNECTOR (RWE02b)

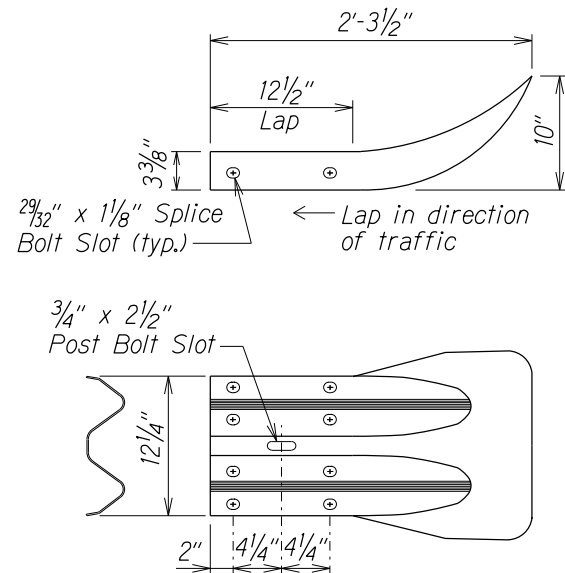

DESIGNATOR	BASE METAL THICKNESS
RWE01a	12 Gauge

W-BEAM END SECTION (FLARED RWE01a)

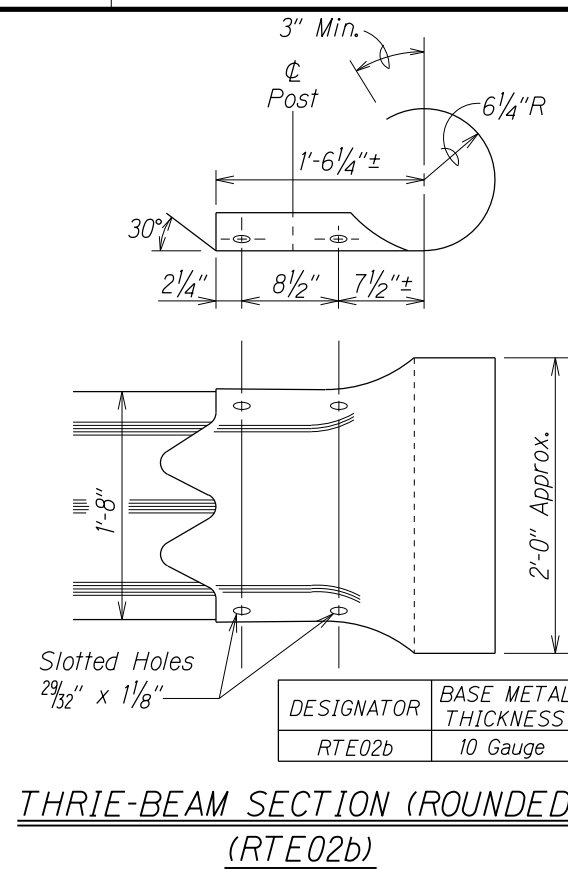

DESIGNATOR	BASE METAL THICKNESS
RTE02b	10 Gauge

THRIE-BEAM SECTION (ROUNDED) (RTE02b)

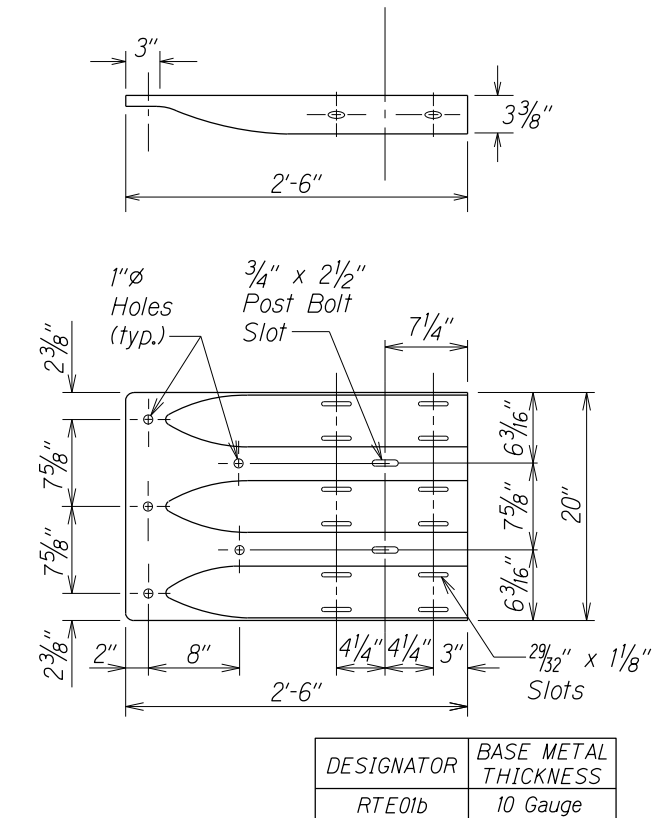

DESIGNATOR	BASE METAL THICKNESS
RTE01b	10 Gauge

THRIE-BEAM TERMINAL CONNECTOR (RTE01b)

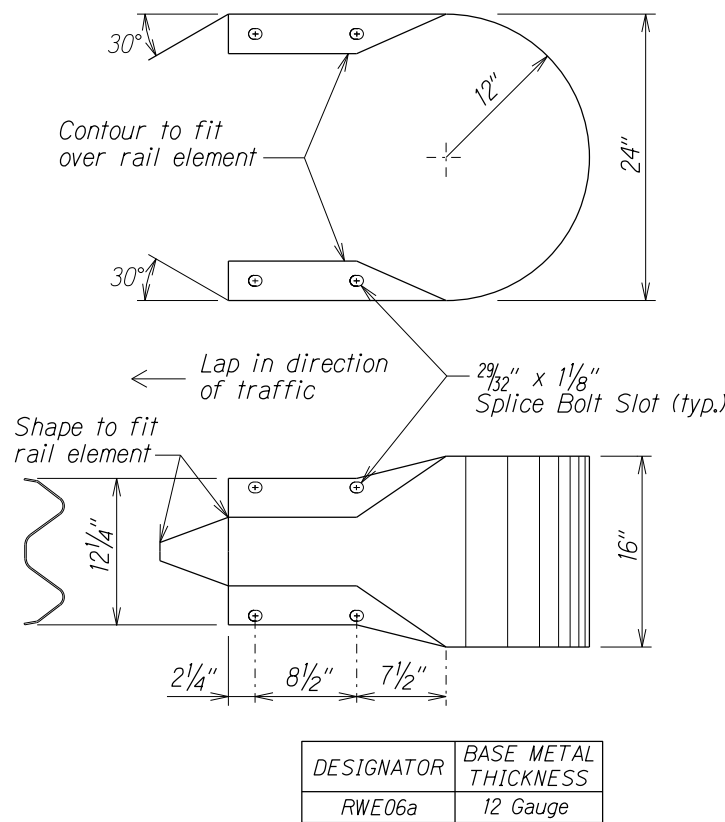

DESIGNATOR	BASE METAL THICKNESS
RWE06a	12 Gauge

W-BEAM END SECTION (BUFFER RWE06a)

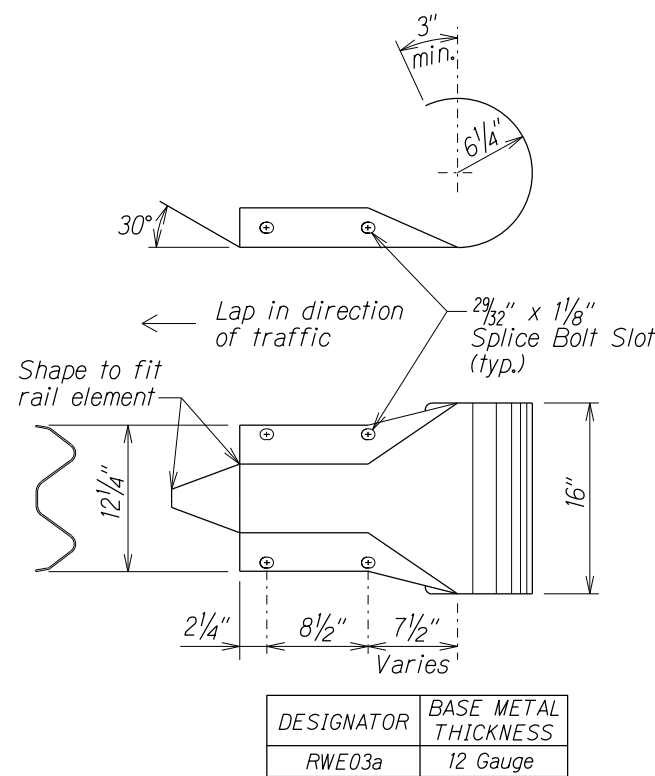

DESIGNATOR	BASE METAL THICKNESS
RWE03a	12 Gauge

W-BEAM END SECTION (ROUNDED RWE03a)

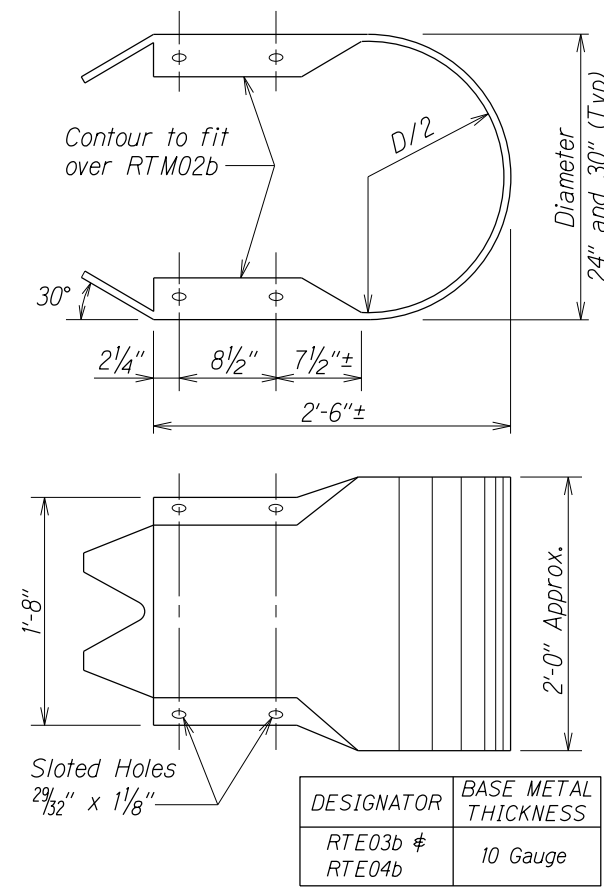

DESIGNATOR	BASE METAL THICKNESS
RTE03b & RTE04b	10 Gauge

THRIE-BEAM END SECTION (BUFFER RTE03b or RTE04b)



STATE OF HAWAII
DEPARTMENT OF TRANSPORTATION
HIGHWAYS DIVISION

GUARDRAIL TERMINAL CONNECTORS AND END SECTIONS

HONOAPIILANI HIGHWAY GUARDRAIL & SHOULDER IMPROVEMENTS
Vicinity of North Kihei Road to Hononana
Federal-Aid Project No. STP-030-1(058)R
Scale: NTS Date: March, 2023

SHEET No. 3 OF 12 SHEETS

SURVEY PLOTTED BY: DATE: 3/23
 DRAWN BY: X
 NOTE BOOK DESIGNED BY: LH
 QUANTITIES BY: X
 CHECKED BY: X
 ORIGINAL PLAN No. X.dgn
 D:\usr2\Ernest\standards\Traffic Guardrail Standards\archive\m4_re51rev.dgn
 12/14/20

FED. ROAD DIST. NO.	STATE	FED. AID PROJ. NO.	FISCAL YEAR	SHEET NO.	TOTAL SHEETS
HAWAII	HAW.	STP-030-1(058)R	2023	12	40

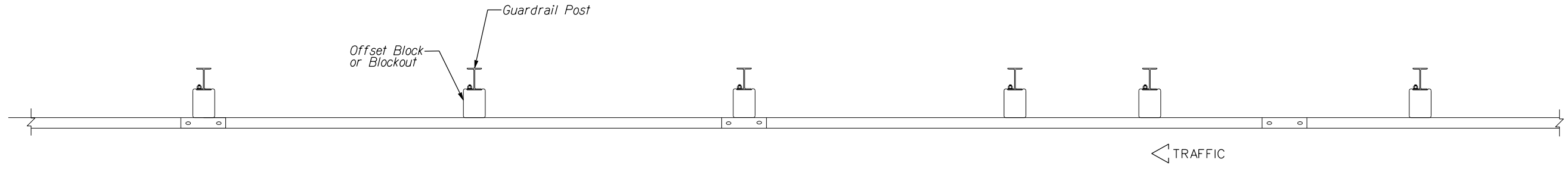

PLAN

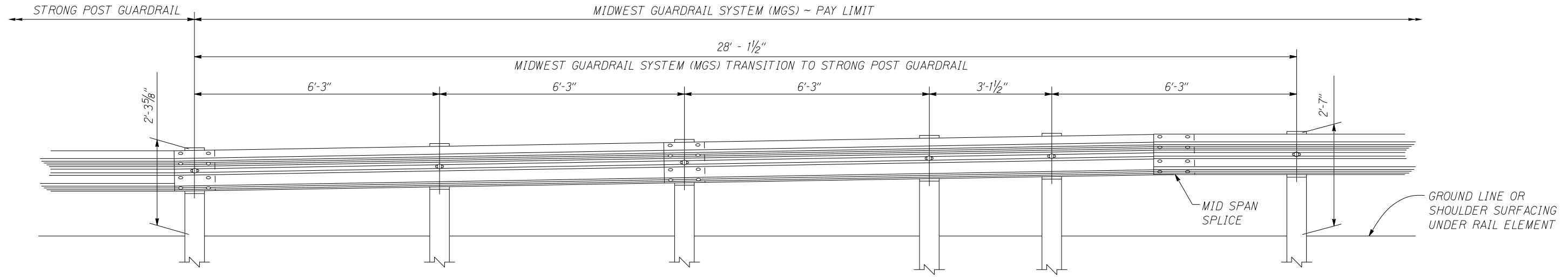

ELEVATION

ORIGINAL PLAN	DATE
NOTED	3/23
DESIGNED BY LH	
QUANTITIES BY	
CHECKED BY	

r09/06/16 D:\st2\Ernest\standards\Traffic Guardrail Standards\ml7_midwest.dgn

STATE OF HAWAII
DEPARTMENT OF TRANSPORTATION
HIGHWAYS DIVISION

**MGS TRANSITION TO
STRONG POST GUARDRAIL**

HONOAPIILANI HIGHWAY GUARDRAIL & SHOULDER IMPROVEMENTS
Vicinity of North Kihei Road to Hononana
Federal-Aid Project No. STP-030-1(058)R
Scale: NTS Date: March, 2023

SHEET No. 4 OF 12 SHEETS

FED. ROAD DIST. NO.	STATE	FED. AID PROJ. NO.	FISCAL YEAR	SHEET NO.	TOTAL SHEETS
HAWAII	HAW.	STP-030-1(058)R	2023	13	40

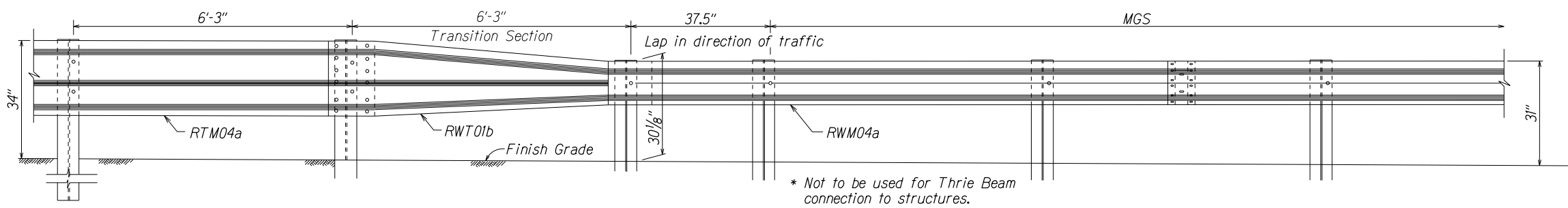

TRANSITION SECTION *

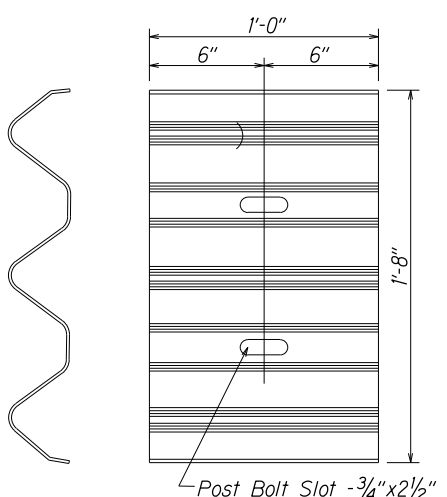

BACKUP PLATE
(RTB01b)
(Use at Posts where Splices do not occur)

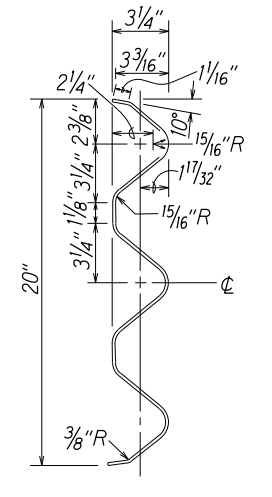

SECTION THRU RAIL ELEMENT
(RTM04a)

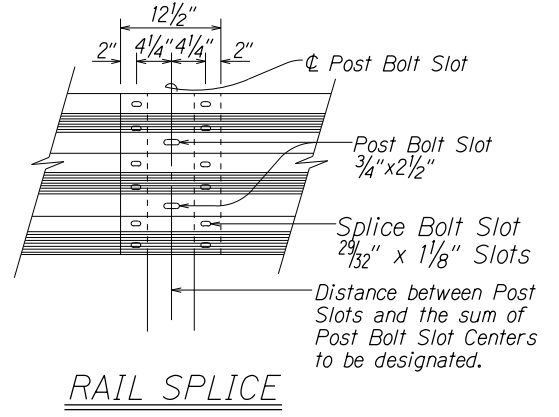

RAIL SPLICE

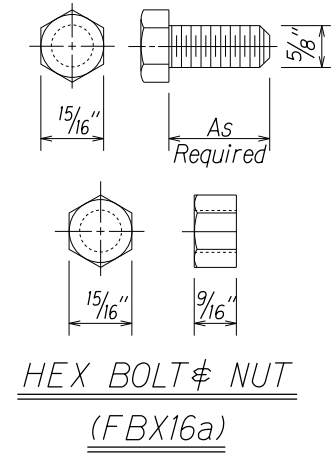
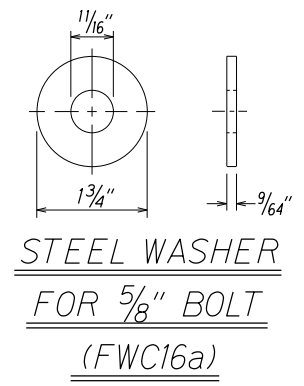

Reflector Marker (RM-5) - Reflector Facing Traffic (Mounted on Guardrail Bolt). For details and notes, see Guardrail Details & Notes sheet.

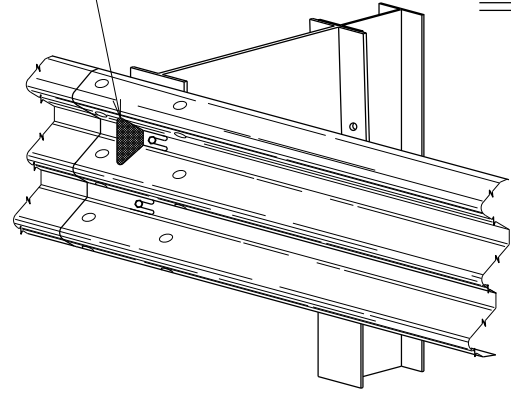

TYPICAL INSTALLATION OF REFLECTOR MARKER (RM-5)

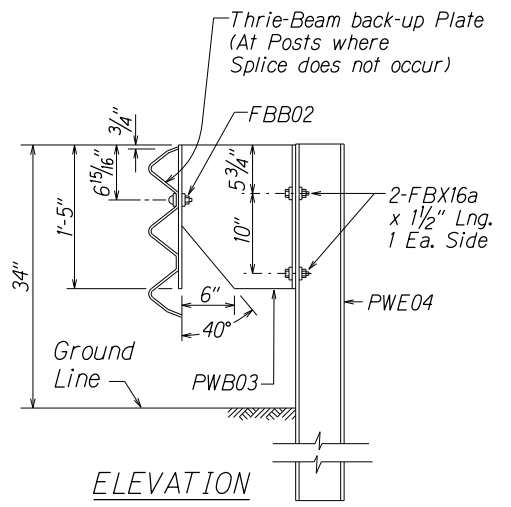
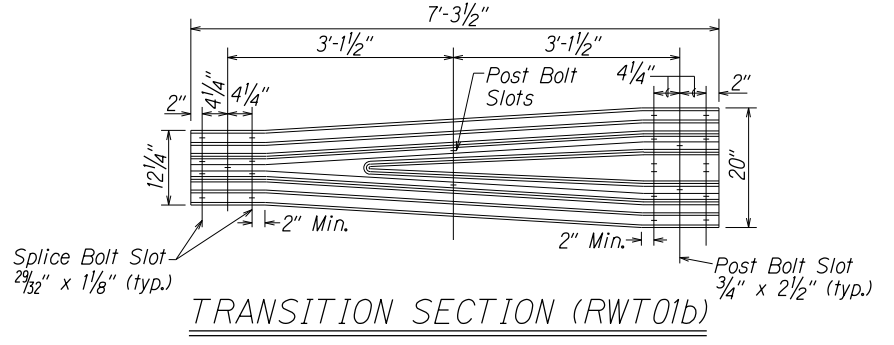
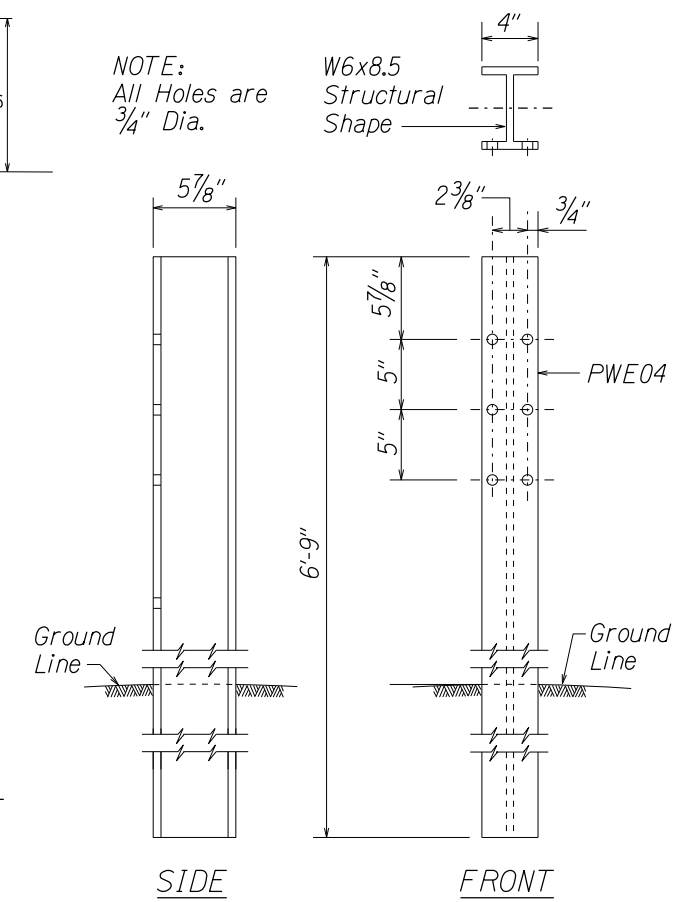

STRONG POST MODIFIED THRIE-BEAM GUARDRAIL
(SGR09b)

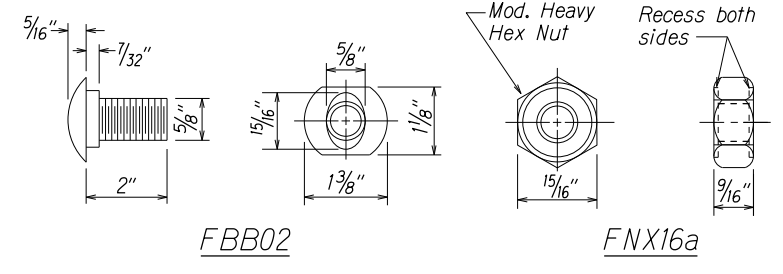
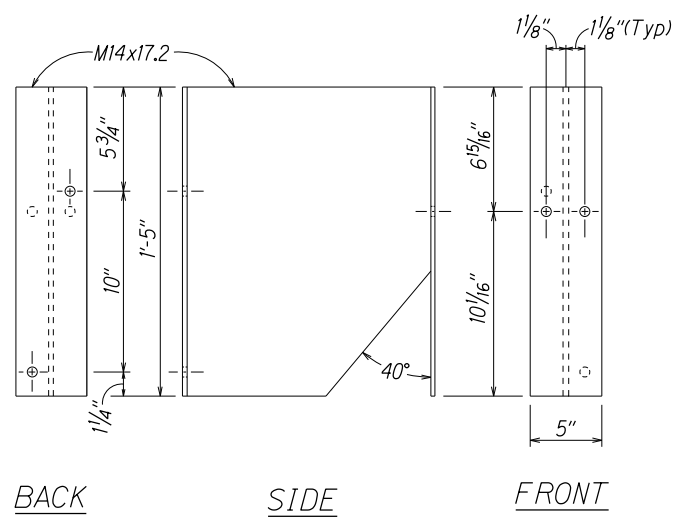

STATE OF HAWAII
DEPARTMENT OF TRANSPORTATION
HIGHWAYS DIVISION

STRONG POST MODIFIED THRIE-BEAM GUARDRAIL (MASH)

HONOAPIILANI HIGHWAY GUARDRAIL & SHOULDER IMPROVEMENTS

Vicinity of North Kihei Road to Hononana

Federal-Aid Project No. STP-030-1(058)R

Scale: NTS Date: March, 2023

SHEET No. 5 OF 12 SHEETS

SURVEY PLOTTED BY	DATE
DRAWN BY	3/23
DESIGNED BY	
QUANTITIES BY	
CHECKED BY	
ORIGINAL PLAN	
NOTE BOOK	
No.	

r4/28/22 idr/cuby/guardrail/modthrie.M-5A.dgn (standard plan TE-5T r11/03/89 & TE-5Ta r11/03/89)

FED. ROAD DIST. NO.	STATE	FED. AID PROJ. NO.	FISCAL YEAR	SHEET NO.	TOTAL SHEETS
HAWAII	HAW.	STP-030-1(058)R	2023	14	40

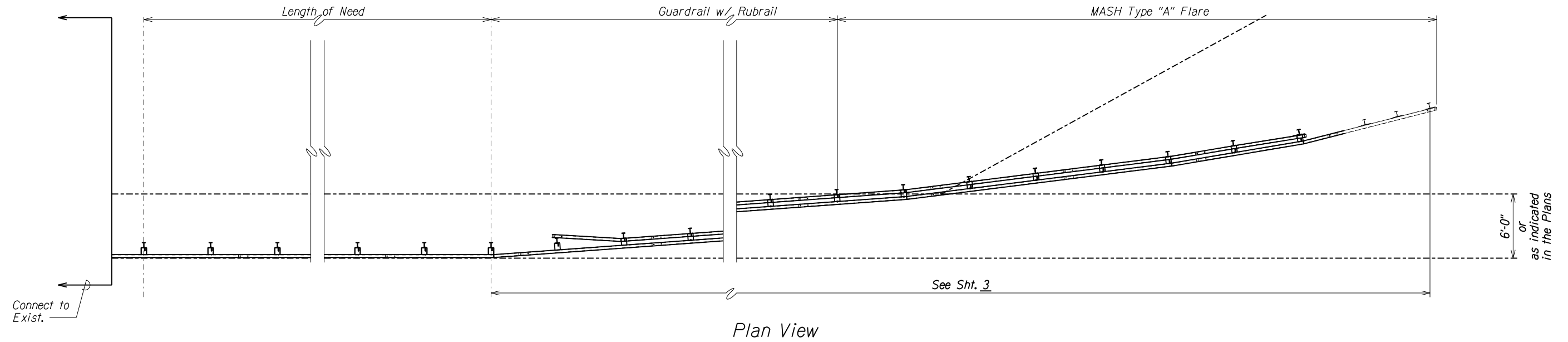

Plan View

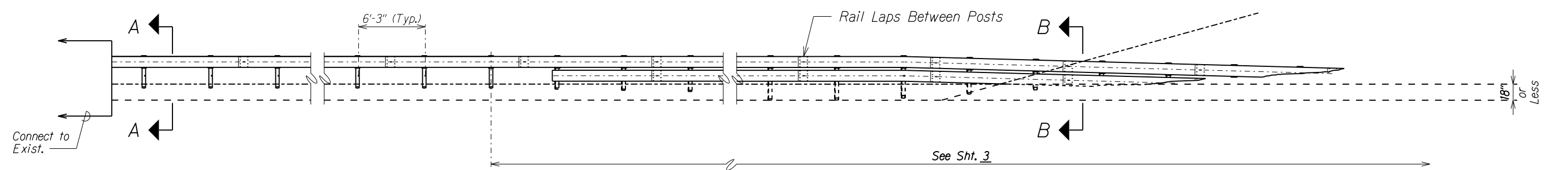

Elevation View

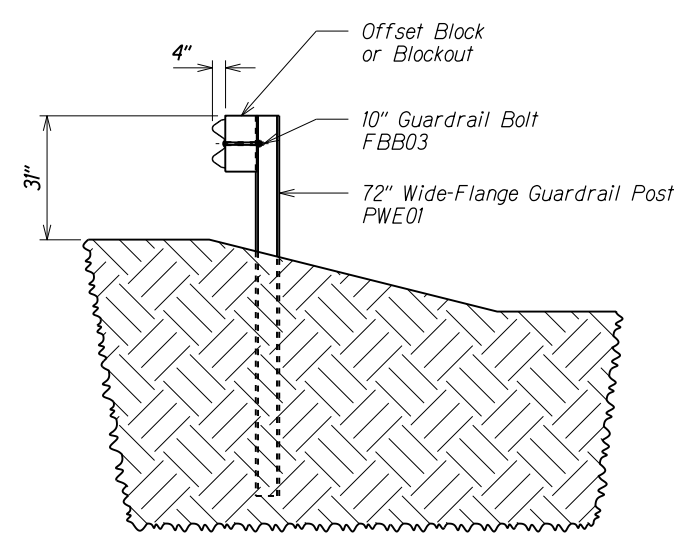

Section A-A

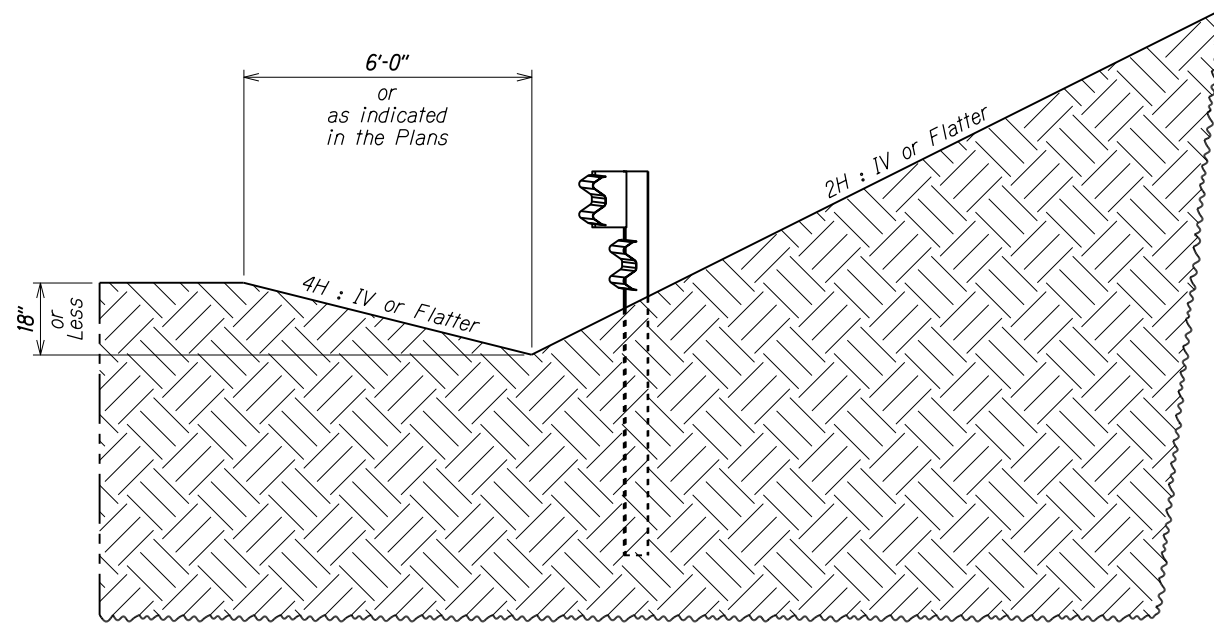

Section B-B

- Notes:
1. Backfill Post holes with AASHTO M147-65(2004), Grade B crushed limestone road base, compacted to MASH standard.
 2. 75" Post spacing typical for LoN and Terminal unless otherwise indicated.

**TERMINAL PLAN & ELEVATION VIEW AND SECTIONS
(BURIED IN BACKSLOPE)**

STATE OF HAWAII
DEPARTMENT OF TRANSPORTATION
HIGHWAYS DIVISION

MASH TYPE "A" FLARE
HONOAPIILANI HIGHWAY
GUARDRAIL & SHOULDER IMPROVEMENTS
Vicinity of North Kihei Road to Hononaha
Federal-Aid Project No. STP-030-1(058)R

Scale: NTS Date: March, 2023

SHEET No. 6 OF 12 SHEETS

SURVEY PLOTTED BY	DATE
DRAWN BY	3/23
DESIGNED BY	
QUANTITIES BY	
CHECKED BY	
ORIGINAL PLAN	
NOTE BOOK	
ddx.x	
x.dgn	

6/09/22 \\dlr\mes\guardrail\M9\MASH-A_Flare-M9A.dgn

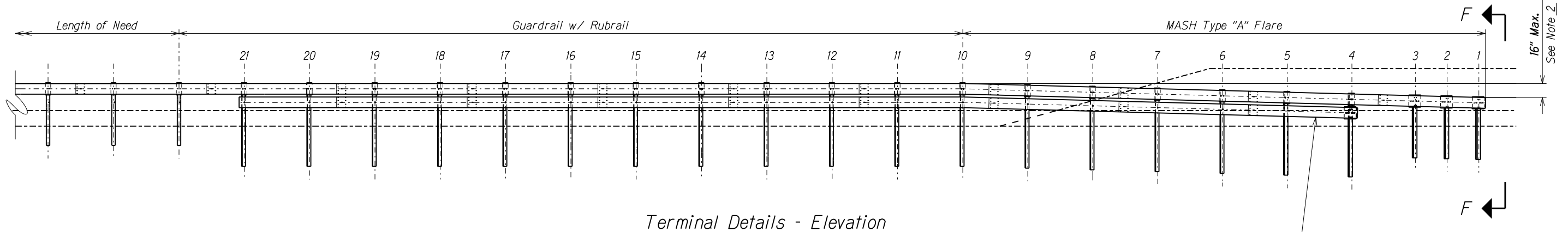

Terminal Details - Elevation

12 ga. W-beam,
9'-4 1/2" Span

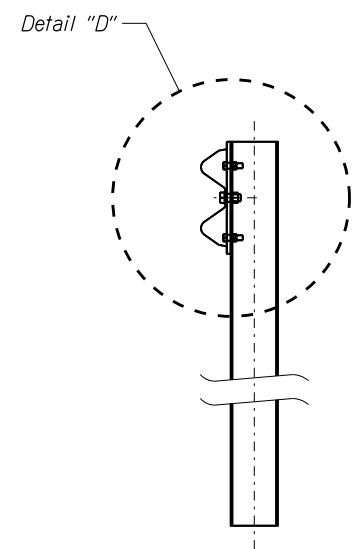

Section E-E

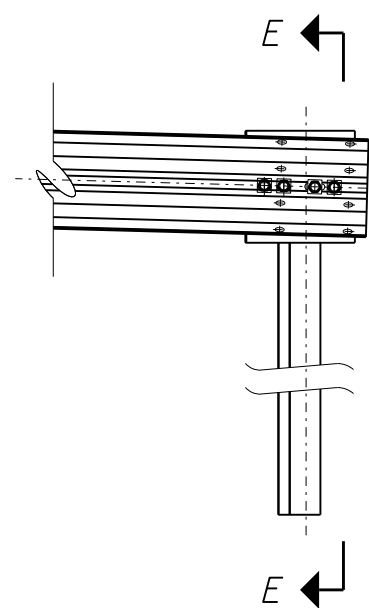

Post 1

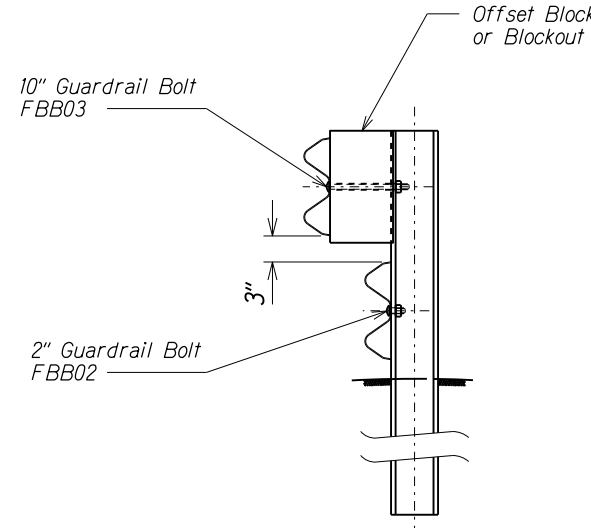

Section G-G

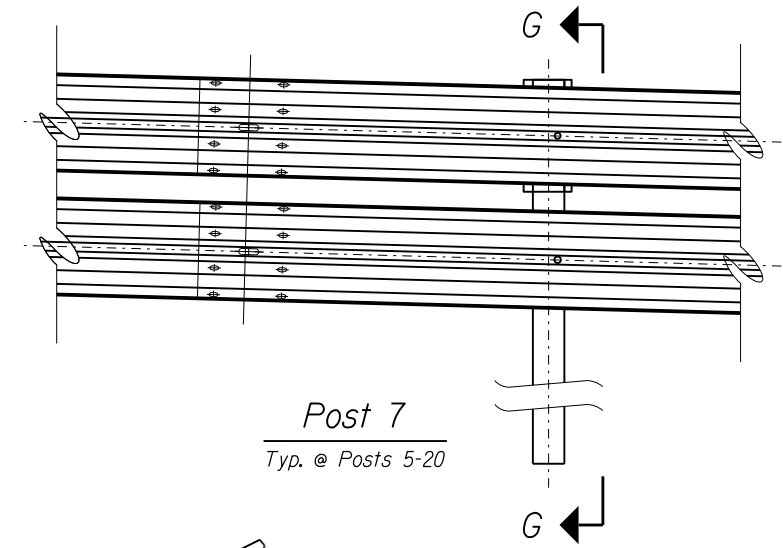

Post 7
Typ. @ Posts 5-20

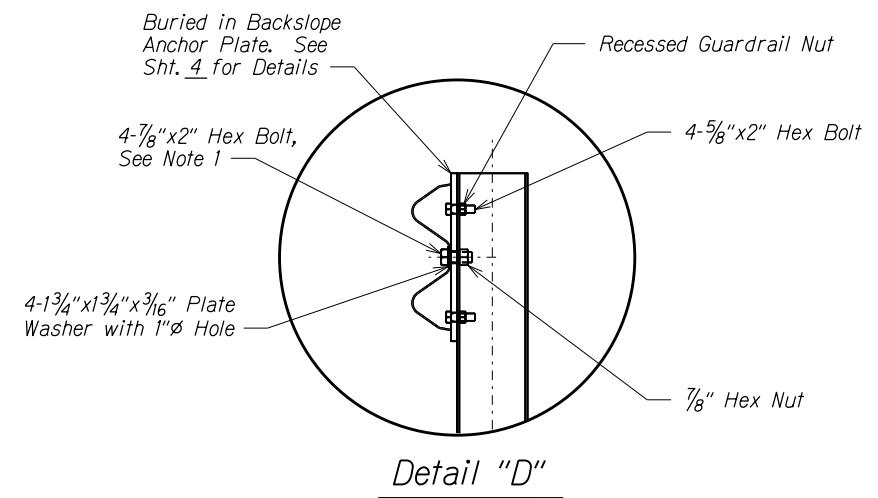

Detail "D"

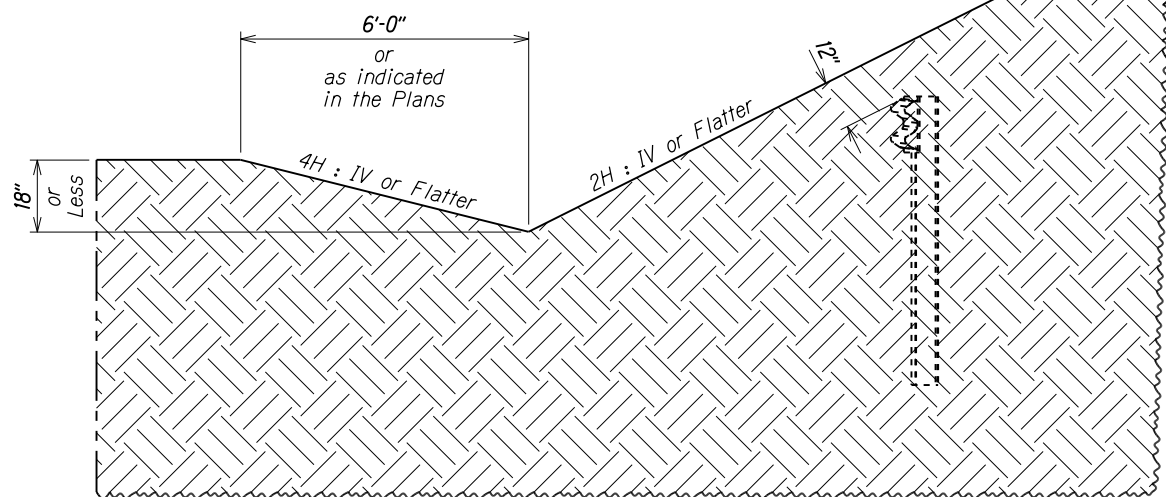

Section F-F

- Notes:
1. Recessed Guardrail Nuts typical on all 5/8" Bolts. Anchor Plate and hardware are typical on top rail at Posts 1-3, and rub rail at Post 4. Field drill 1" holes in Guardrail as needed for 1/8" Bolts at Posts 1-4. Hex head bolts are ASTM A307.
 2. Rail height changes 16" Maximum from Post 10 to 1 to achieve 12" of soil coverage at Post 1.

TERMINAL ELEVATION & DETAILS
(BURIED IN BACKSLOPE)

STATE OF HAWAII
DEPARTMENT OF TRANSPORTATION
HIGHWAYS DIVISION

MASH TYPE "A" FLARE
HONOAPIILANI HIGHWAY
GUARDRAIL & SHOULDER IMPROVEMENTS
Vicinity of North Kihei Road to Hononana
Federal-Aid Project No. STP-030-1(058)R

Scale: NTS Date: March, 2023

SHEET No. 7 OF 12 SHEETS

SURVEY PLOTTED BY	DATE
9/22	
DESIGNED BY	
QUANTITIES BY	
CHECKED BY	
ORIGINAL PLAN	
NOTE BOOK	
ddx.x	
X.dgn	

6/09/22 \\dlErnest\guardrail\M9\MASH-A_Flare-M9B.dgn

FED. ROAD DIST. NO.	STATE	FED. AID PROJ. NO.	FISCAL YEAR	SHEET NO.	TOTAL SHEETS
HAWAII	HAW.	STP-030-1(058)R	2023	16	40

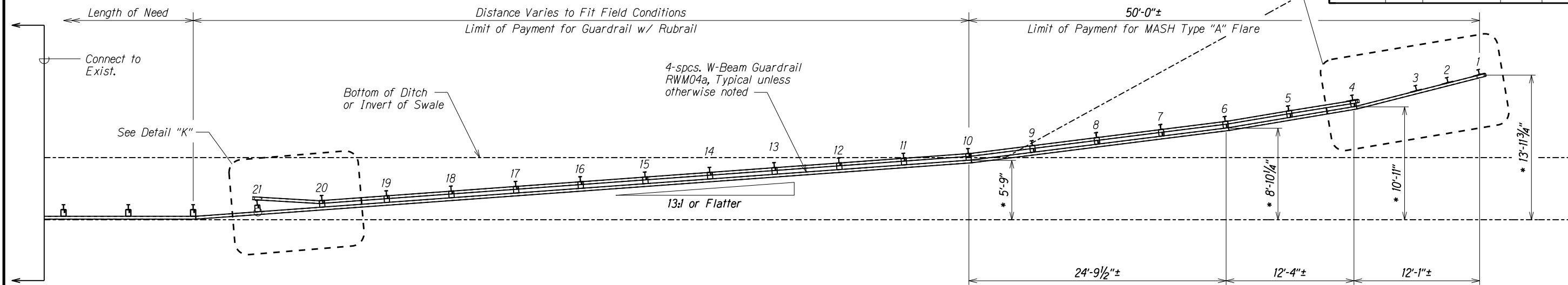

Terminal Details - Plan

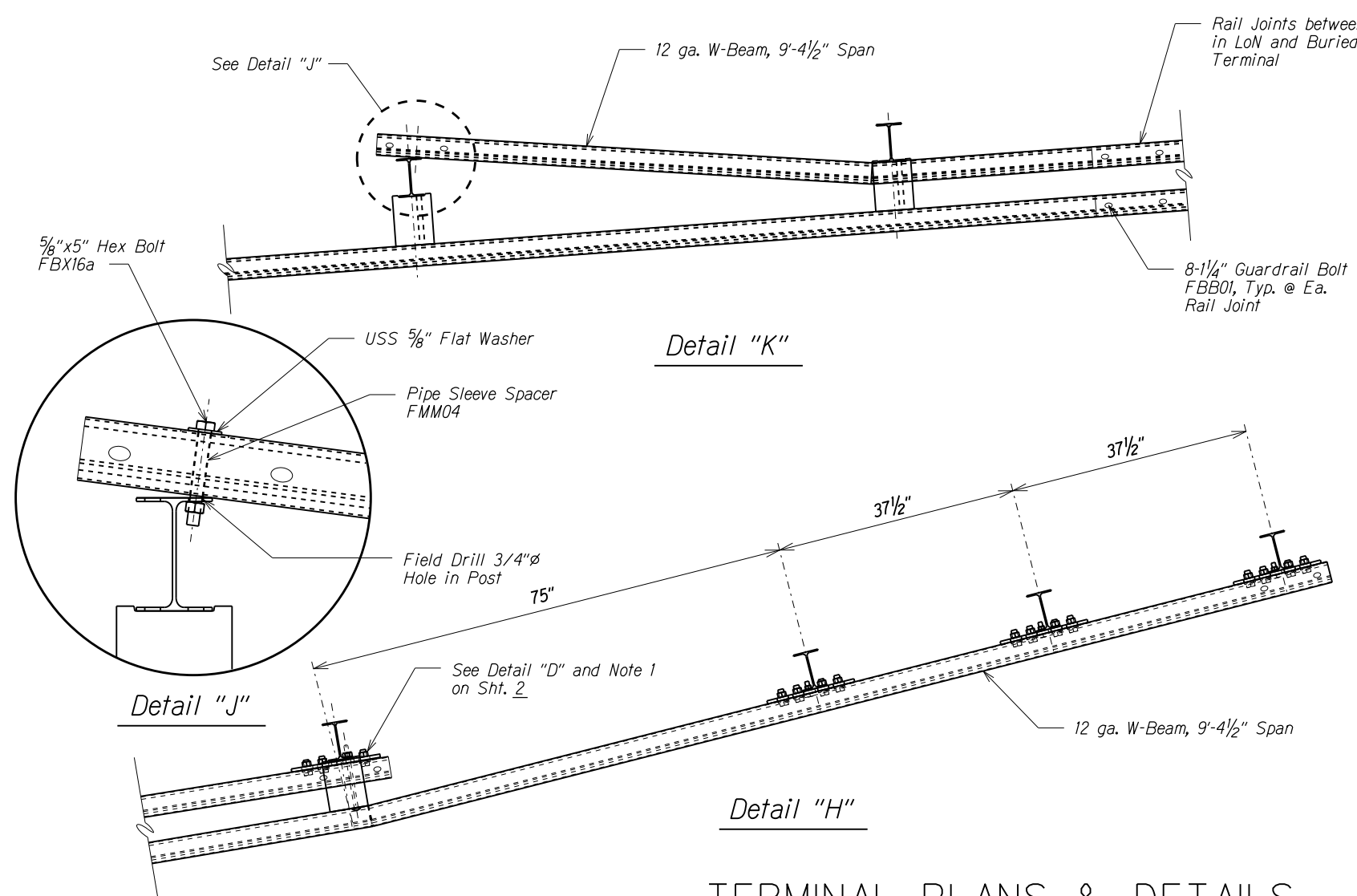

Detail "K"

Detail "H"

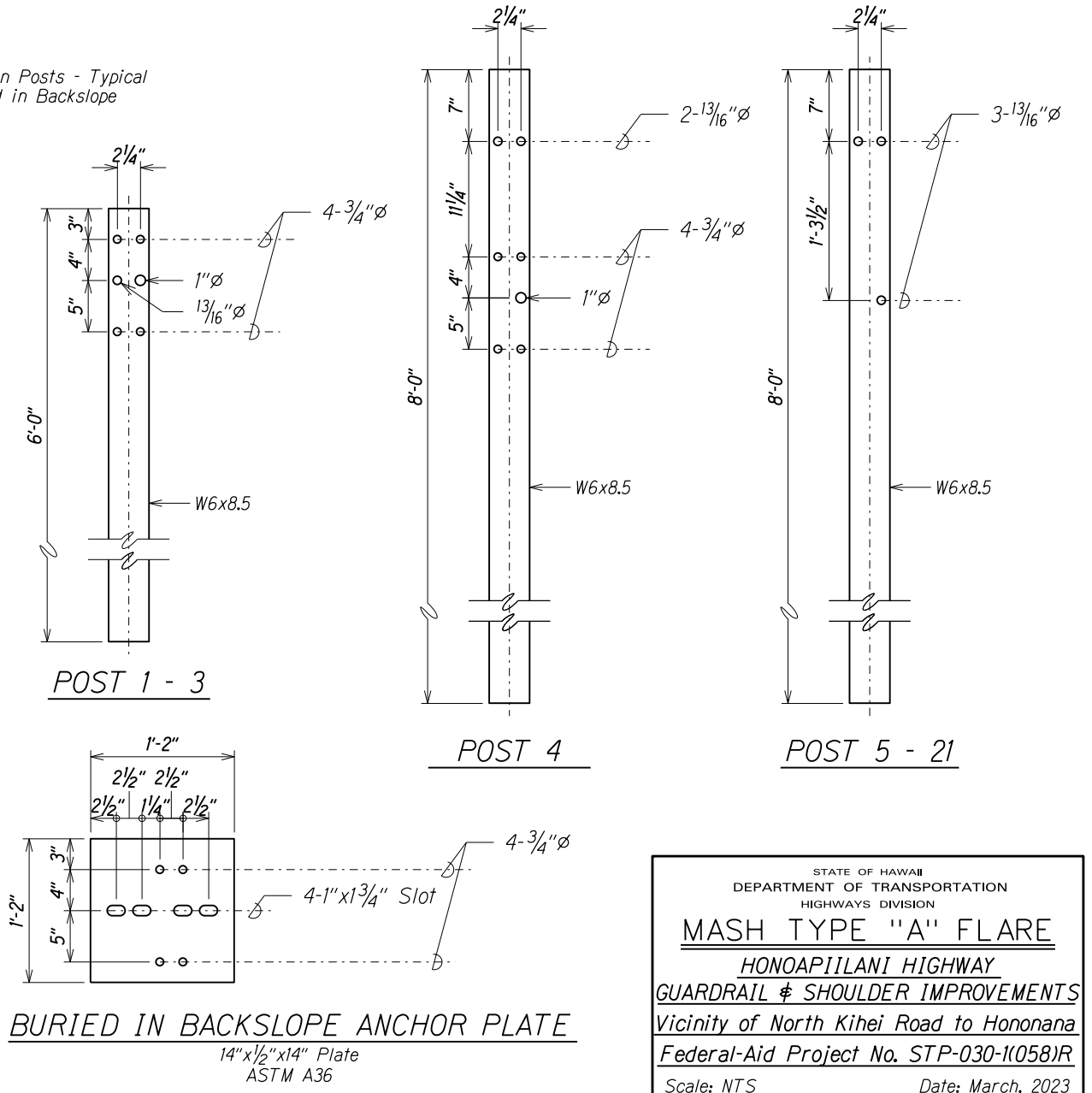

POST 1 - 3

POST 4

POST 5 - 21

BURIED IN BACKSLOPE ANCHOR PLATE

14" x 1/2" x 14" Plate
ASTM A36

TERMINAL PLANS & DETAILS
(BURIED IN BACKSLOPE)

Note:
1. * These dimensions indicate the offset to the back of the Rail at Posts 1, 4, 6 and 10, based on a 6'-0" Wide Ditch or Swale foreslope.

SURVEY PLOTTED BY	DATE
DRAWN BY	3/23
DESIGNED BY	
QUANTITIES BY	
CHECKED BY	
ORIGINAL PLAN	
NOTE BOOK	
ddx.x	
X.dgn	

6/09/22 \\dlE:\nest\guardrail\M9\MASH_L_Flare-M9C.dgn

STATE OF HAWAII
DEPARTMENT OF TRANSPORTATION
HIGHWAYS DIVISION

MASH TYPE "A" FLARE
HONOAPIILANI HIGHWAY
GUARDRAIL & SHOULDER IMPROVEMENTS
Vicinity of North Kihei Road to Hononana
Federal-Aid Project No. STP-030-1(058)R

Scale: NTS Date: March, 2023

SHEET No. 8 OF 12 SHEETS

General Notes

- All posts are 6'-0" in length within the 50'-0" pay limit for the Modified Type "A-1" Flare without rubrail.
- Whenever swales or a change in grade is encountered within the 50'-0" pay limit for the Modified Type "A-1" Flare, a rubrail shall be installed and all posts shall have a minimum embedment of 4'-0". Post lengths shall be adjusted to provide the minimum embedment.
- All fasteners, posts, blocks and rail elements shall conform to the latest edition and amendments of "A Guide to Standardized Highway Barrier Rail Hardware", a report prepared and approved by the AASHTO-AGCARTBA Joint Cooperative Committee and HDOT's Statewide Guideline for Permanent Highway Safety Hardware.
- Limit of payment for Modified Type "A-1" Flare shall be 50'-0" from End Shoe including Rubrail (when applicable), Anchor Block and GRP work.
- Excavation, Anchor Block, Backfill and GRP work shall be considered incidental to the Modified Type "A-1" Flare.

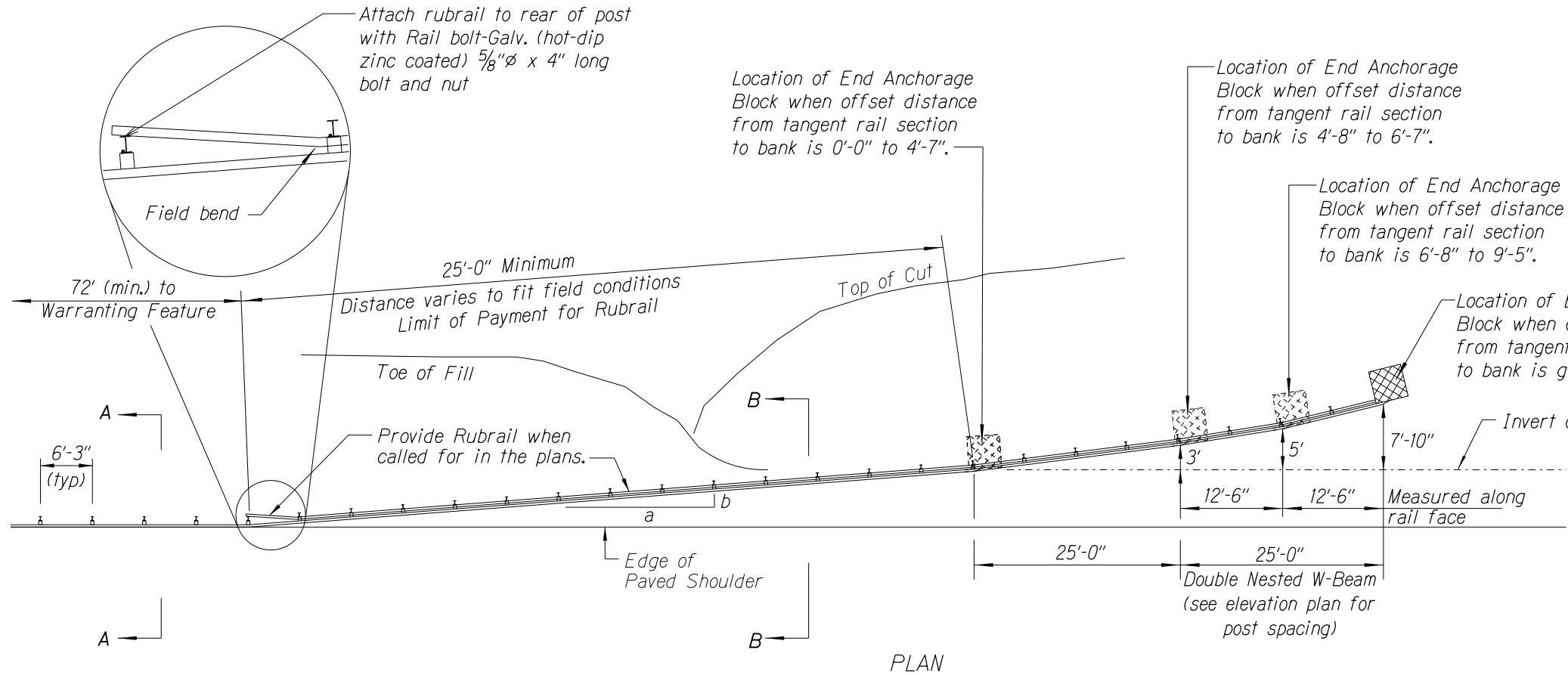

Design speed mph	a:b
68	15:1
62	13:1
56	12:1
50	11:1
43	10:1
37	9:1
31	7:1

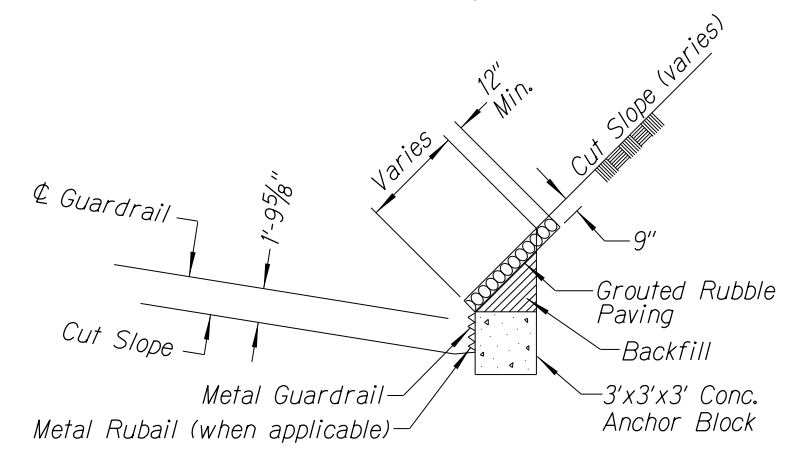
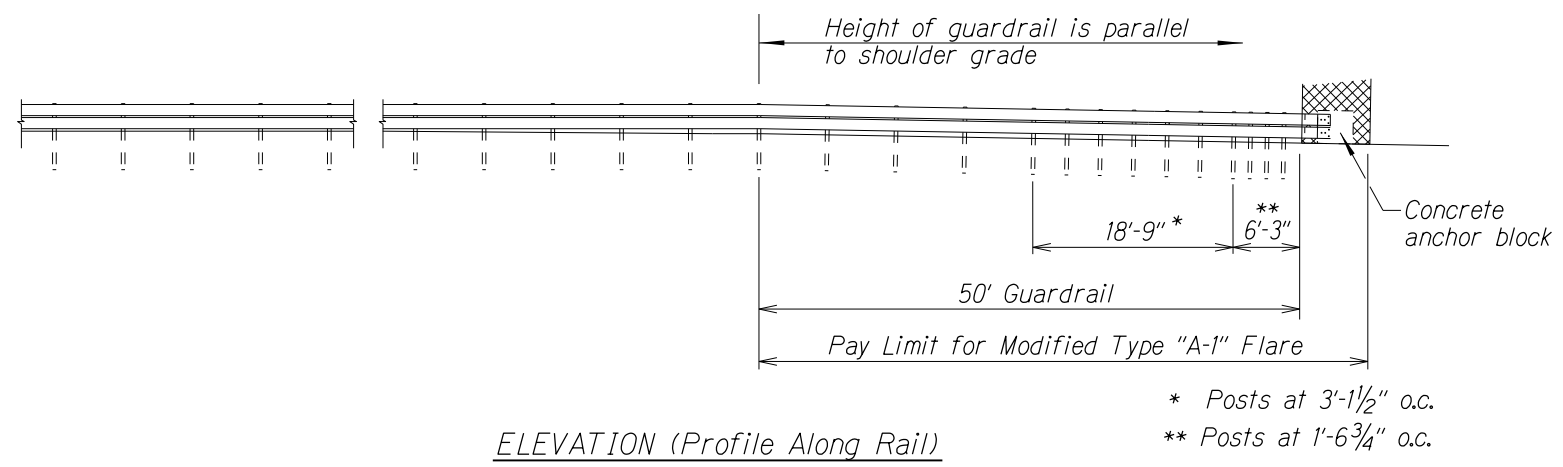

ANCHOR BLOCK IN CUT SECTION

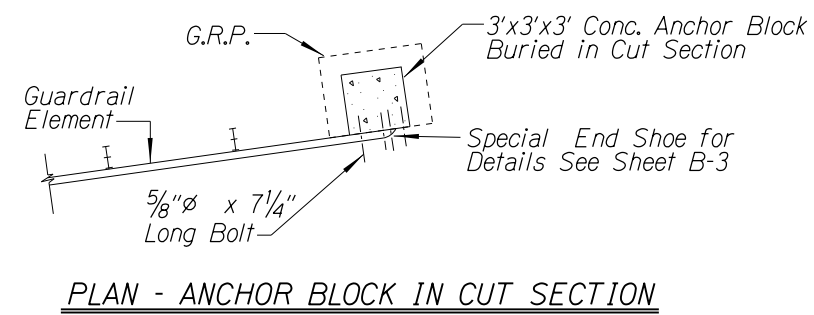
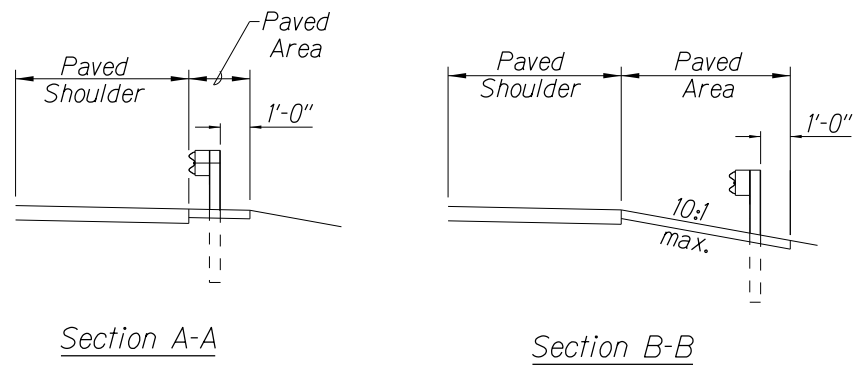

PLAN - ANCHOR BLOCK IN CUT SECTION

STATE OF HAWAII
DEPARTMENT OF TRANSPORTATION
HIGHWAYS DIVISION

MODIFIED TYPE "A-1" FLARE

HONOAPIILANI HIGHWAY
GUARDRAIL & SHOULDER IMPROVEMENTS
Vicinity of North Kihei Road to Hononana
Federal-Aid Project No. STP-030-1(058)R

Scale: NTS Date: March, 2023

SHEET No. 9 OF 12 SHEETS

SURVEY PLOTTED BY: DATE: 3/23
 DRAWN BY: X
 DESIGNED BY: LH
 QUANTITIES BY: X
 CHECKED BY: X
 ORIGINAL PLAN: X
 NOTE BOOK: X
 No. X

(standard plan TE-58 07/01/86, TE-59 11/03/89 & TE-60 07/01/86)
 r8/21/01 tdl,ruby/guardrail/flare_al_ldgn

FED. ROAD DIST. NO.	STATE	FED. AID PROJ. NO.	FISCAL YEAR	SHEET NO.	TOTAL SHEETS
HAWAII	HAW.	STP-030-1(058)R	2023	18	40

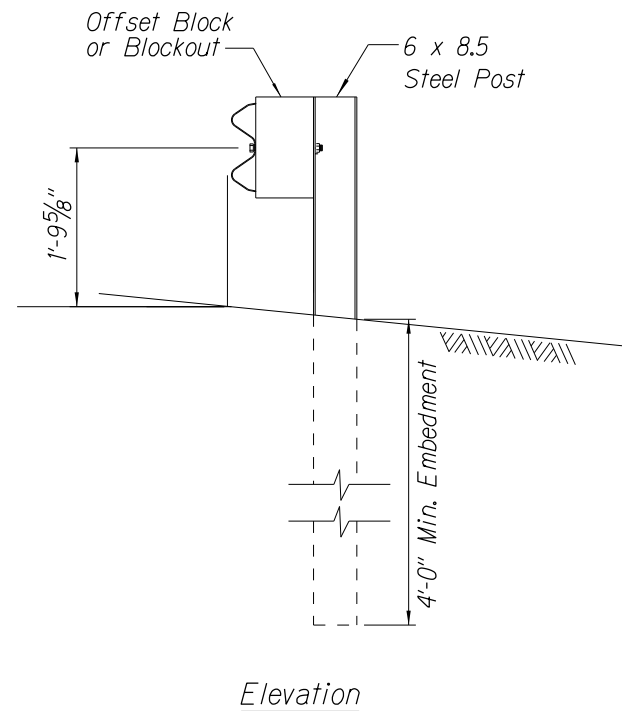
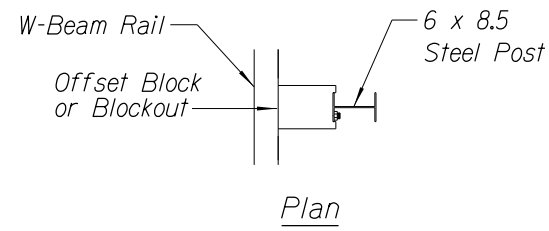

STRONG POST W-BEAM GUARDRAIL

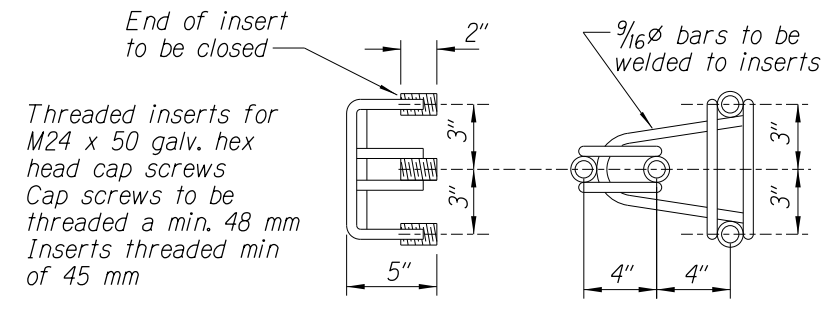

**ANCHOR ASSEMBLY
CONCRETE BLOCK ANCHOR**

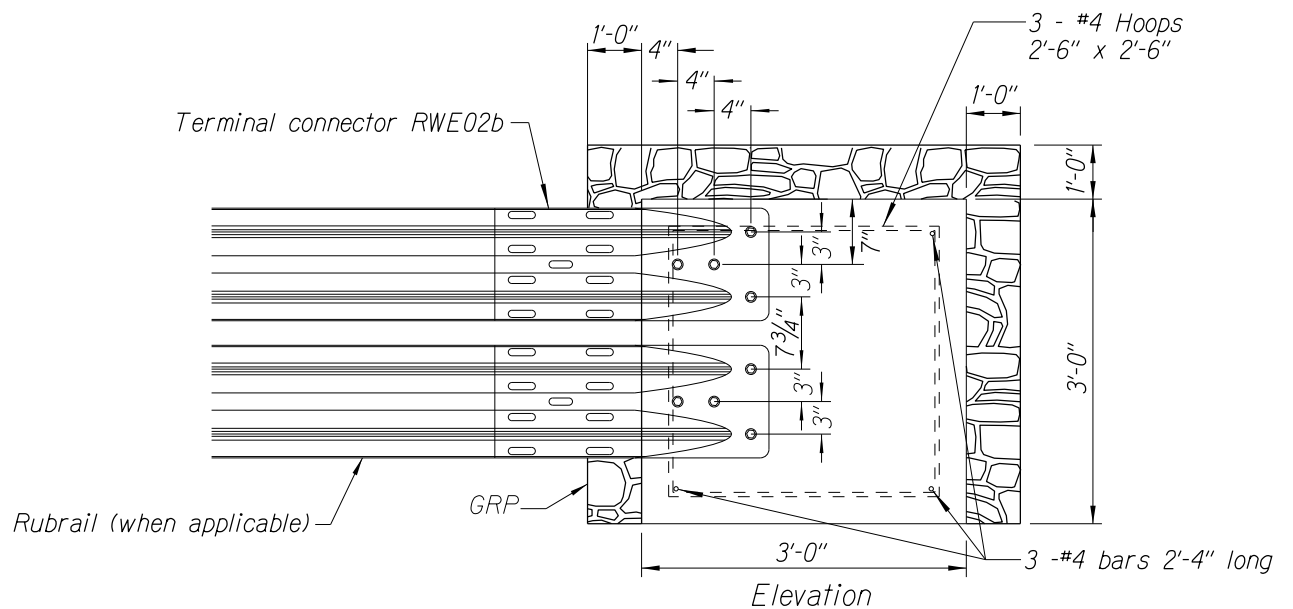
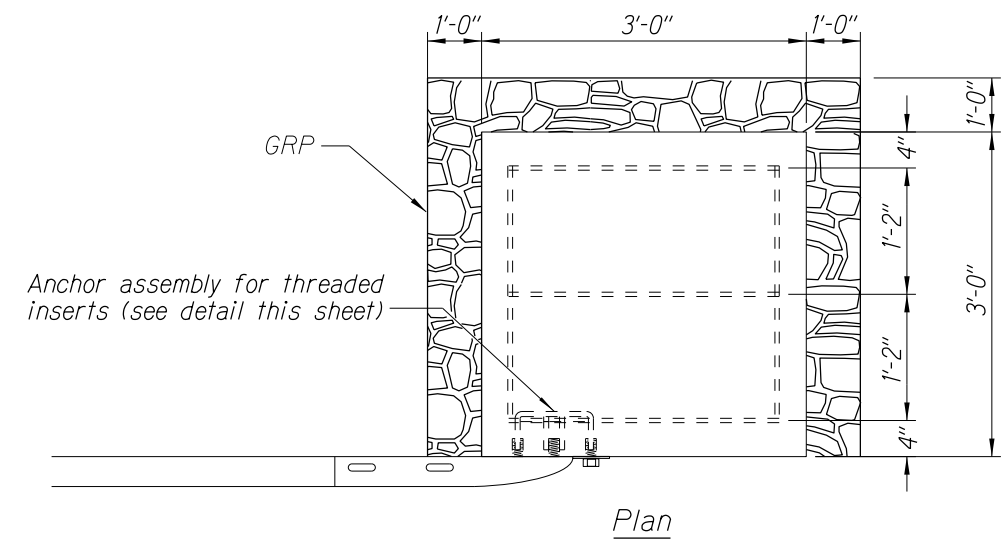

**CONCRETE BLOCK ANCHOR
(3' X 3' X 3')**

**BACKSLOPE ANCHOR TERMINAL END ANCHORAGE DETAILS
MODIFIED TYPE "A-1" FLARE**

Note:
All fasteners, posts, blocks and rail elements shall conform to the latest edition and amendments of "A Guide to Standardized Highway Barrier Rail Hardware," a report prepared and approved by the AASHTO-AGCARTBA Joint Cooperative Committee and HDOT's Statewide Guideline for Permanent Highway Safety Hardware.

ORIGINAL PLAN	DATE
	3/23
DESIGNED BY	LH
CHECKED BY	

r5/2/01 tdlrubby/guardrail/flare_al_2.dgn (standard plan TE-58 07/01/86, TE-59 r11/03/89 & TE-60 07/01/86)

STATE OF HAWAII
DEPARTMENT OF TRANSPORTATION
HIGHWAYS DIVISION
MODIFIED TYPE "A-1" FLARE
HONOAPIILANI HIGHWAY
GUARDRAIL & SHOULDER IMPROVEMENTS
Vicinity of North Kihei Road to Hononana
Federal-Aid Project No. STP-030-1(058)R
Scale: NTS Date: March, 2023
SHEET No. 10 OF 12 SHEETS

FED. ROAD DIST. NO.	STATE	FED. AID PROJ. NO.	FISCAL YEAR	SHEET NO.	TOTAL SHEETS
HAWAII	HAW.	STP-030-1(058)R	2023	19	40

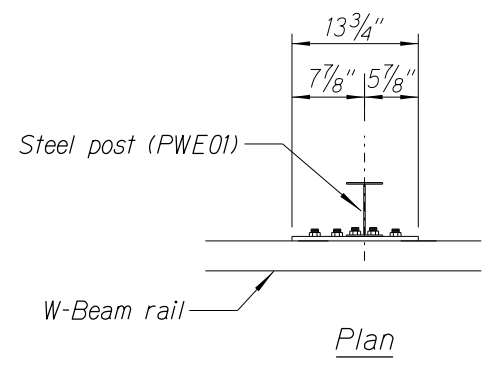
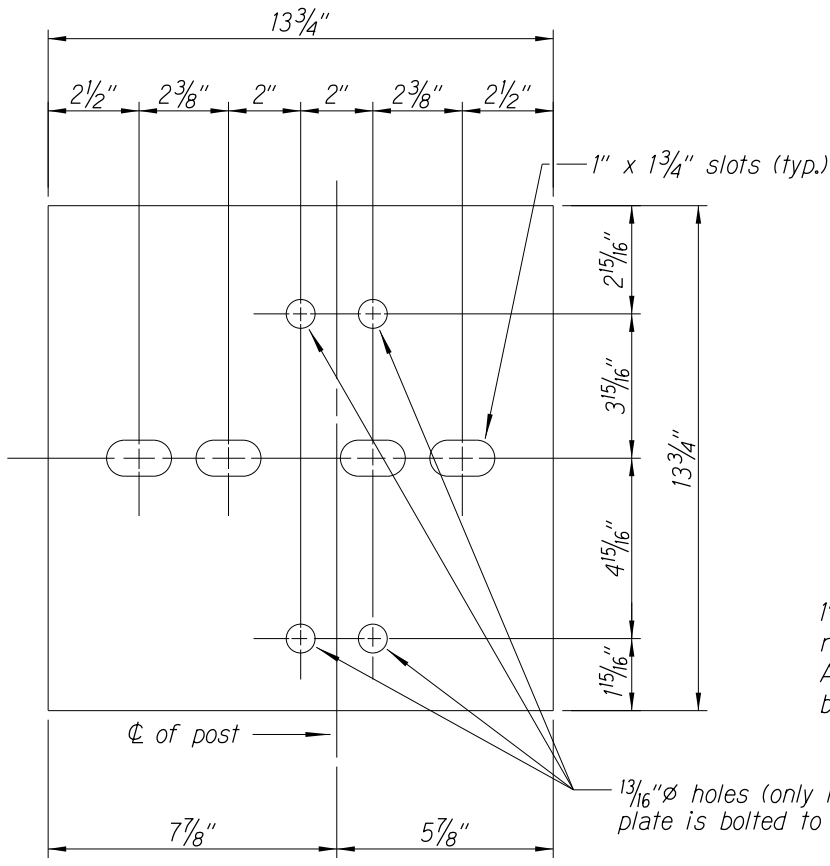

3 - 7/8" ϕ holes to be field drilled in rail and attached to steel plate with 7/8" ϕ hex bolts 1 5/16" long with square washer

1" ϕ holes to be field drilled in rail and through post flange. Attach to steel plate with 7/8" ϕ hex bolts 2" long with square washer

1 3/16" ϕ holes (only if plate is bolted to post)

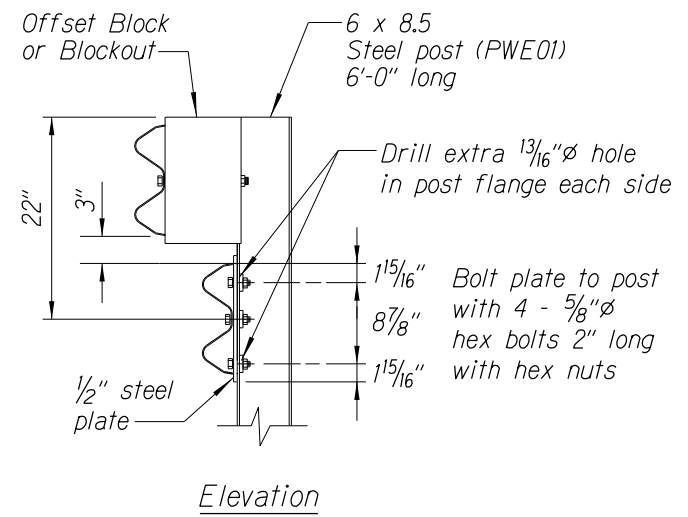
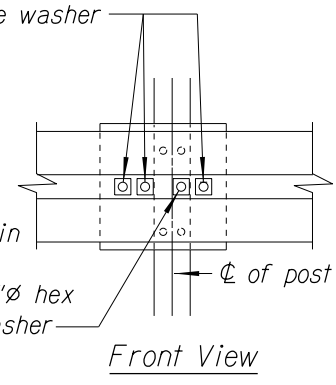

RUBRAIL ANCHOR DETAILS

Steel Plate - 1/2"
(Hot-dip Zinc Coated Galvanized-Welded or Bolted to Post)

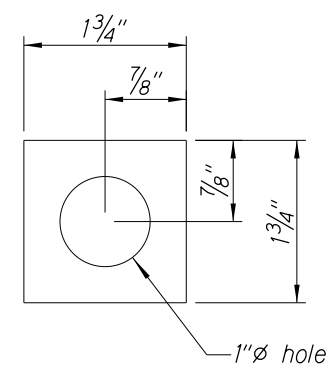

Square Washer
(3/16" Thick - Hot-dip Zinc Coated Galvanized)

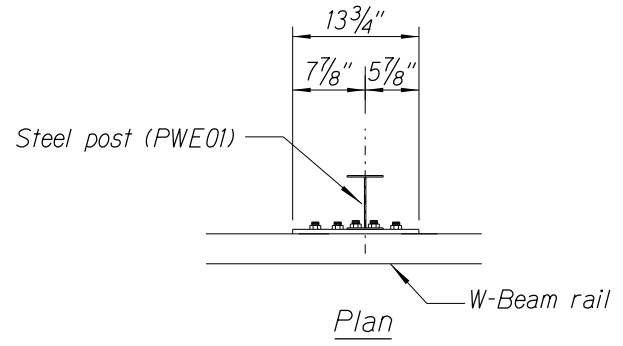

3 - 7/8" ϕ holes to be field drilled in rail and attached to steel plate with 7/8" ϕ hex bolts 1 5/16" long with square washer

1" ϕ holes to be field drilled in rail and through post flange. Attach to steel plate with 7/8" ϕ hex bolts 2" long with square washer

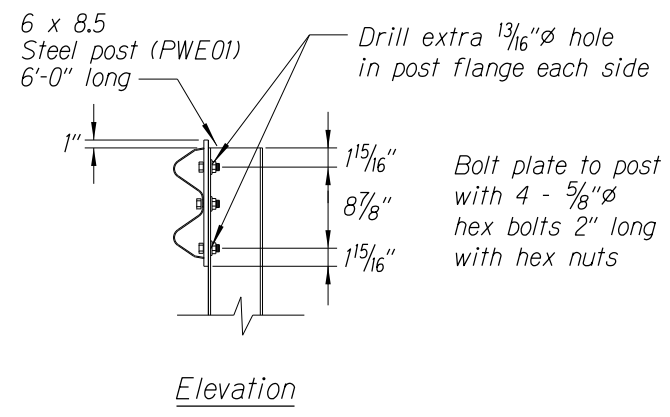
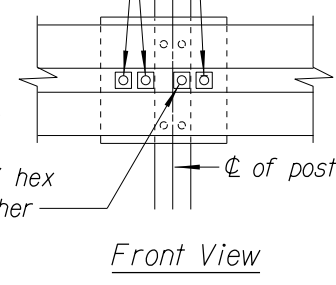

POST ANCHOR DETAILS

RUBRAIL DETAIL FOR MODIFIED TYPE "A-1" FLARE (WHEN CALLED FOR IN PLANS)

Note:
All fasteners, posts, blocks and rail elements shall conform to the latest edition and amendments of "A Guide to Standardized Highway Barrier Rail Hardware", a report prepared and approved by the AASHTO-AGCARTBA Joint Cooperative Committee.

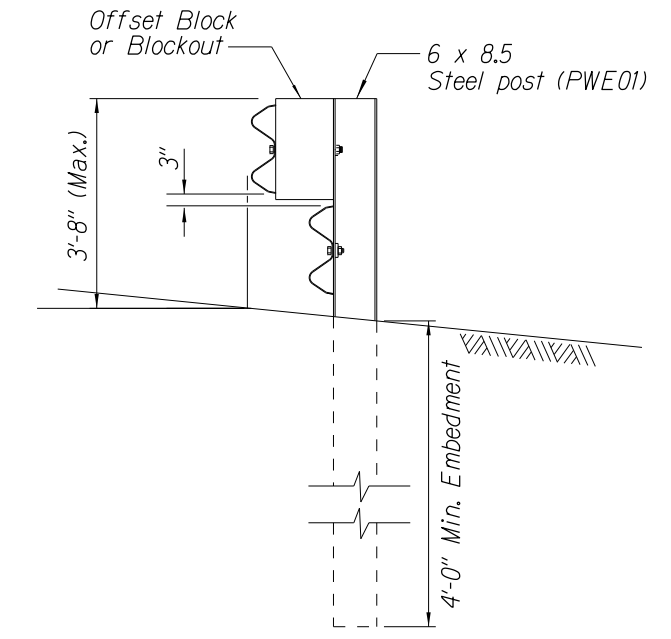
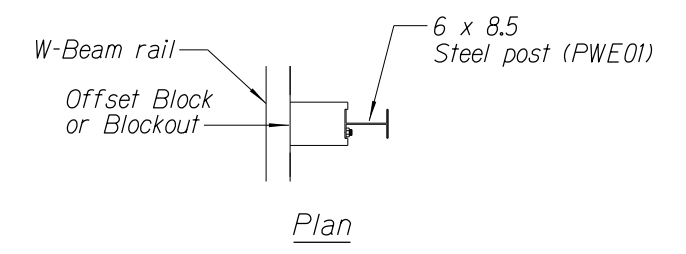

STEEL POST GUARDRAIL WITH RUBRAIL

STATE OF HAWAII
DEPARTMENT OF TRANSPORTATION
HIGHWAYS DIVISION
MODIFIED TYPE "A-1" FLARE
RUBRAIL DETAILS
HONOAPIILANI HIGHWAY GUARDRAIL & SHOULDER IMPROVEMENTS
Vicinity of North Kihei Road to Hononana
Federal-Aid Project No. STP-030-1(058)R
Scale: As Noted Date: March, 2023
SHEET No. 11 OF 12 SHEETS

SURVEY PLOTTED BY	DATE
DRAWN BY	3/23
DESIGNED BY	
QUANTITIES BY	
CHECKED BY	
ORIGINAL PLAN	
NOTE BOOK	X
	X

r5/2/01 rd/ruby/guardrail/flare.al_3.dgn

FED. ROAD DIST. NO.	STATE	FED. AID PROJ. NO.	FISCAL YEAR	SHEET NO.	TOTAL SHEETS
HAWAII	HAW.	STP-030-1(058)R	2023	20	40

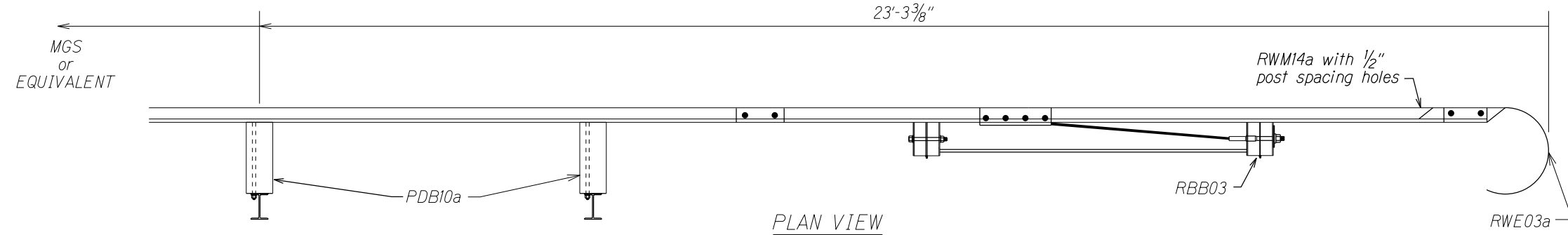

PLAN VIEW

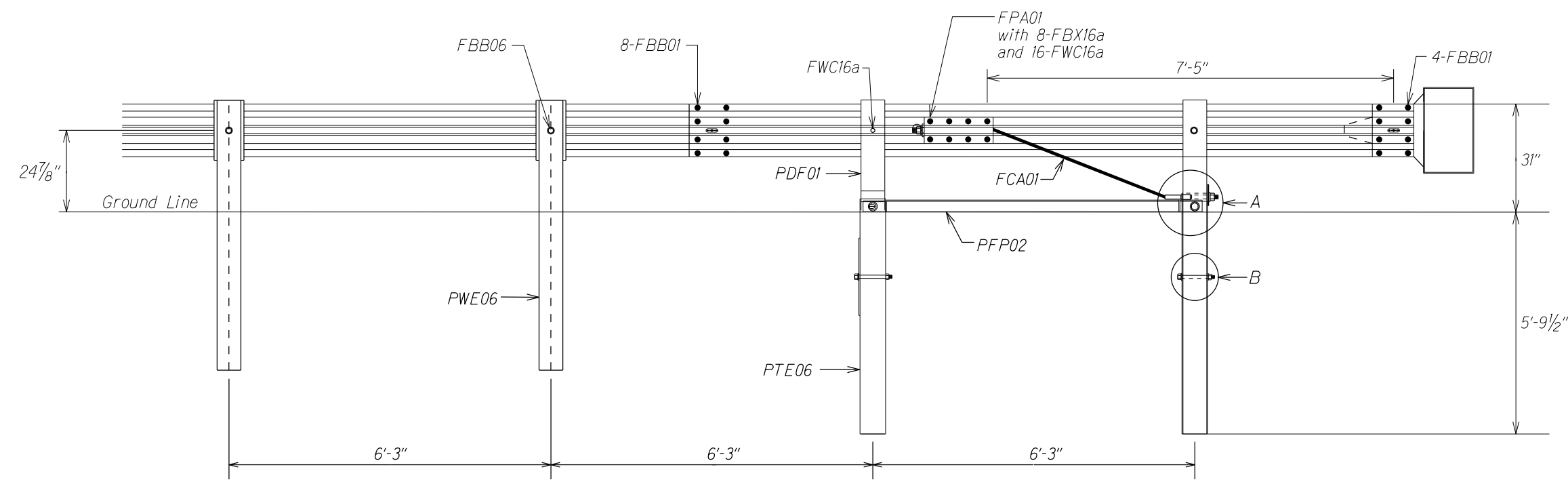

ELEVATION VIEW
NON TRAFFIC SIDE

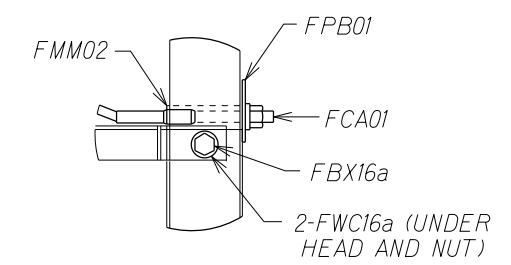

DETAIL A

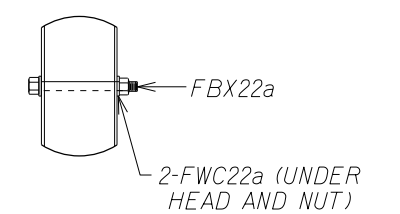

DETAIL B

ITEM NO.	QTY	COMPONENTS
FBB01	12	Guardrail Bolt and Nut
FBB03	2	Guardrail Bolt and Nut
FBB06	1	Guardrail Bolt and Nut
FBX16a	2	Hex Head Bolt (10") and Nut
FBX16a	8	Hex Head Bolt (1 1/2") and Nut
FBX22a	2	Hex Head Bolt (7 1/2") and Nut
FCA01	1	BCT Anchor Cable Assembly
PDB10a	2	MGS Timber Blockout
PFP02	1	Strut and Yoke Assembly
PWE06	1	Wide-Flange Guardrail Post
FMM02	1	BCT Post Sleeve
FPA01	1	Anchor Bracket Assembly
FPB01	1	BCT Bearing Plate
FWC16a	22	Circular Washer
FWC22a	4	Circular Washer
PDF01	2	BCT Timber Post
PTE06	2	Foundation Tube
RWE03a	1	W-Beam Rounded End Section
RWM14a	1	W-Beam MGS End Section

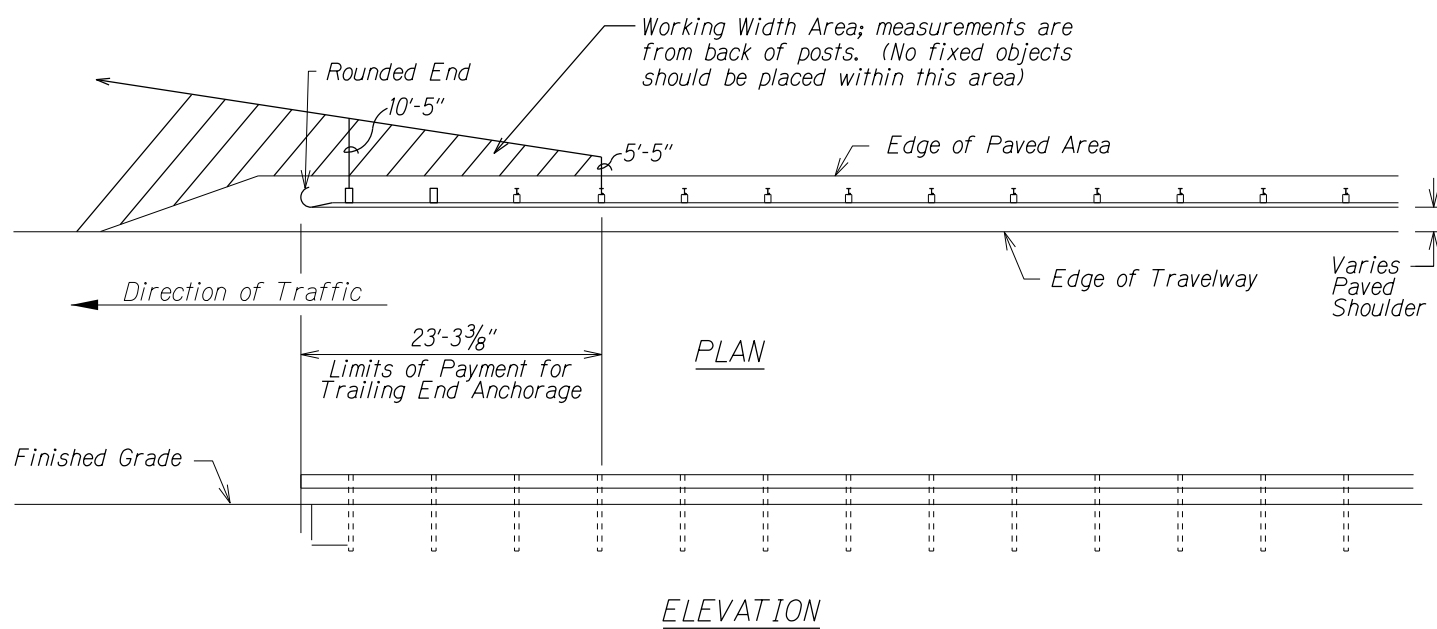

ELEVATION

STATE OF HAWAII
DEPARTMENT OF TRANSPORTATION
HIGHWAYS DIVISION

TRAILING-END ANCHORAGE SYSTEM

HONOAPIILANI HIGHWAY GUARDRAIL & SHOULDER IMPROVEMENTS
Vicinity of North Kihei Road to Hononana
Federal-Aid Project No. STP-030-1(058)R
Scale: NTS Date: March, 2023

SURVEY PLOTTED BY: DATE: 3/23
 DRAWN BY: LH
 DESIGNED BY: LH
 QUANTITIES BY: X
 CHECKED BY: X
 ORIGINAL PLAN: X
 NOTE BOOK: X
 No. X

r11/6/17 rd2m/guardrail/M-8

FED. ROAD DIST. NO.	STATE	FED. AID PROJ. NO.	FISCAL YEAR	SHEET NO.	TOTAL SHEETS
HAWAII	HAW.	STP-030-1(058)R	2023	21	40

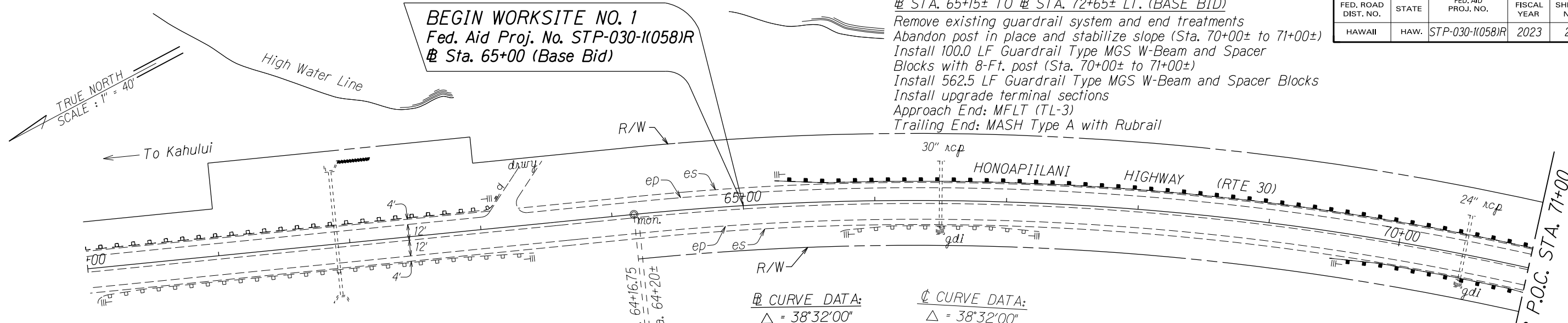

BEGIN WORKSITE NO. 1
 Fed. Aid Proj. No. STP-030-1(058)R
 @ Sta. 65+00 (Base Bid)

@ STA. 65+15± TO @ STA. 72+65± LT. (BASE BID)
 Remove existing guardrail system and end treatments
 Abandon post in place and stabilize slope (Sta. 70+00± to 71+00±)
 Install 100.0 LF Guardrail Type MGS W-Beam and Spacer Blocks with 8-Ft. post (Sta. 70+00± to 71+00±)
 Install 562.5 LF Guardrail Type MGS W-Beam and Spacer Blocks
 Install upgrade terminal sections
 Approach End: MFLT (TL-3)
 Trailing End: MASH Type A with Rubrail

⊕ CURVE DATA:
 $\Delta = 38^\circ 32' 00''$
 $\frac{\Delta}{2} = 19^\circ 16' 00''$
 $R = 2,147.42'$
 $T = 750.61'$
 $C = 1,417.15'$
 $Lc = 1,444.21'$
 $D.C. = 02^\circ 40' 00''$

⊖ CURVE DATA:
 $\Delta = 38^\circ 32' 00''$
 $R = 2,147.42'$
 $Lc = 1,444.21'$

@ STA. 69+55± TO @ STA. 71+30± RT. (BASE BID)
 Remove existing guardrail system and end treatments
 Install 75.0 LF Guardrail Type MGS W-Beam and Spacer Blocks
 Install upgrade terminal sections
 Approach End: MASH Type A with Rubrail
 Trailing End: MASH Type A with Rubrail

@ STA. 72+85± TO @ STA. 79+85± LT. (BASE BID)
 Remove existing guardrail system and end treatments
 Install 625.0 LF Guardrail Type MGS W-Beam and Spacer Blocks
 Install upgrade terminal sections
 Approach End: MASH Type A with Rubrail
 Trailing End: Trailing-End Anchor System

⊕ CURVE DATA:
 $\Delta = 26^\circ 08' 00''$
 $\frac{\Delta}{2} = 13^\circ 04' 00''$
 $R = 1,637.10'$
 $T = 379.96'$
 $C = 740.25'$
 $Lc = 746.70'$
 $D.C. = 03^\circ 30' 00''$

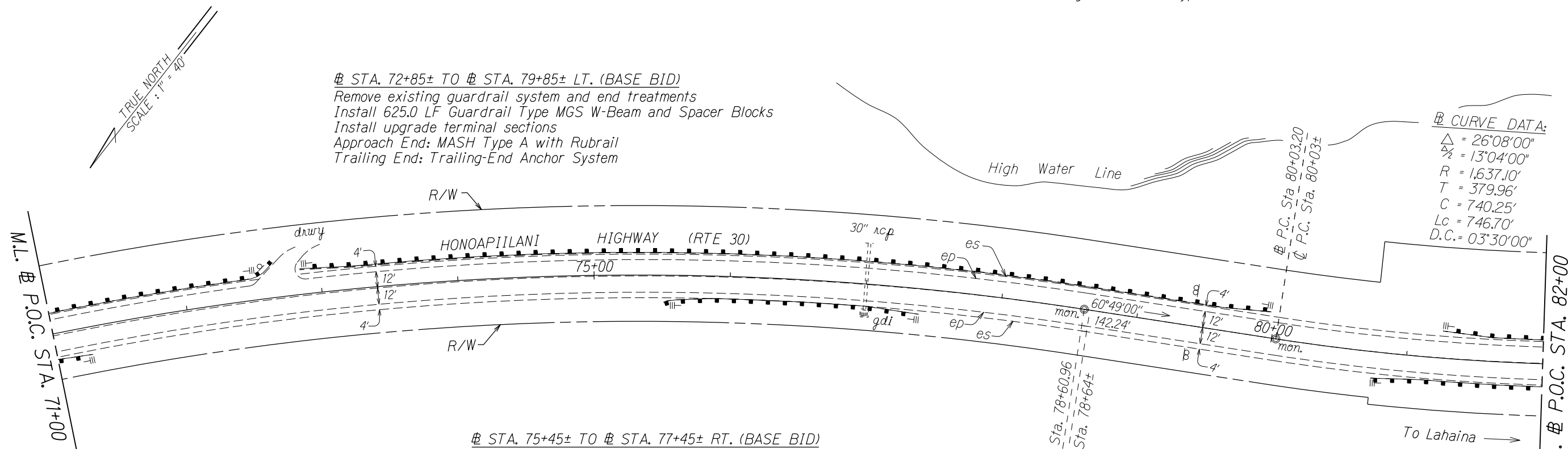

@ STA. 75+45± TO @ STA. 77+45± RT. (BASE BID)
 Remove existing guardrail system and end treatments
 Install 100.0 LF Guardrail Type MGS W-Beam and Spacer Blocks
 Install upgrade terminal sections
 Approach End: MASH Type A with Rubrail
 Trailing End: MASH Type A with Rubrail

NOTE: Install New Type MGS standard 6-Ft. guardrail post or 8-Ft. guardrail post as required to adequately secure new guardrail system. Contractor shall abandon existing guardrail post in place as determined necessary to avoid damage to existing shoulder and/or slope area behind guardrail. Existing guardrail post to be abandoned in place shall be cut flush or below ground surface.

SURVEY PLOTTED BY	DATE
DRAWN BY	3/23
DESIGNED BY	
QUANTITIES BY	
CHECKED BY	

STATE OF HAWAII
 DEPARTMENT OF TRANSPORTATION
 HIGHWAYS DIVISION

ROADWAY PLANS
HONOAPIILANI HIGHWAY
GUARDRAIL & SHOULDER IMPROVEMENTS
 Vicinity of North Kihei Road to Hononana
 Federal-Aid Project No. STP-030-1(058)R

Scale: 1" = 40' Date: March, 2023

SHEET No. 1 OF 17 SHEETS

FED. ROAD DIST. NO.	STATE	FED. AID PROJ. NO.	FISCAL YEAR	SHEET NO.	TOTAL SHEETS
HAWAII	HAW.	STP-030-1(058)R	2023	22	40

± STA. 81+20± TO ± STA. 83+55± LT. (BASE BID)

Remove existing guardrail system and end treatments
 Abandon post in place and stabilize slope (Sta. 81+85± to 82+85±)
 Install 100.0 LF Guardrail Type MGS W-Beam and Spacer Blocks with 8-Ft. post (Sta. 81+85± to 82+85±)
 Install 37.5 LF Guardrail Type MGS W-Beam and Spacer Blocks
 Install upgrade terminal sections
 Approach End: MASH Type A with Rubrail
 Trailing End: MSKT-SP-MGS8(TL-3)

± CURVE DATA:
 $\Delta = 25^{\circ}53'21''$
 $R = 1,594.17'$
 $Lc = 720.33'$

± STA. 85+25± TO ± STA. 93+25± LT. (BASE BID)

Remove existing guardrail system and end treatments
 Install 712.5 LF Guardrail Type MGS W-Beam and Spacer Blocks
 Install upgrade terminal sections
 Approach End: MFLT (TL-3)
 Trailing End: MASH Type A with Rubrail

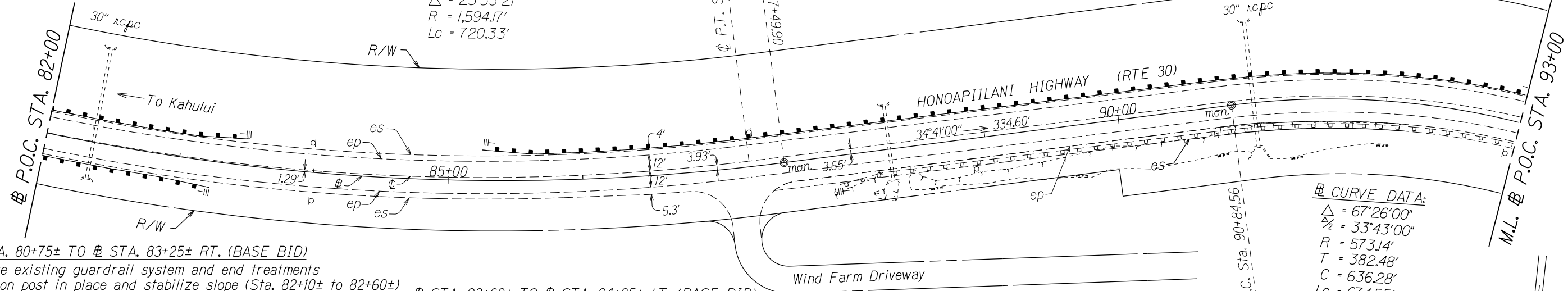

± CURVE DATA:
 $\Delta = 67^{\circ}26'00''$
 $\frac{\Delta}{2} = 33^{\circ}43'00''$
 $R = 573.14'$
 $T = 382.48'$
 $C = 636.28'$
 $Lc = 674.55'$
 $D.C. = 10^{\circ}00'00''$

± STA. 80+75± TO ± STA. 83+25± RT. (BASE BID)

Remove existing guardrail system and end treatments
 Abandon post in place and stabilize slope (Sta. 82+10± to 82+60±)
 Install 50.0 LF Guardrail Type MGS W-Beam and Spacer Blocks with 8-Ft. post (Sta. 82+10± to 82+60±)
 Install 100.0 LF Guardrail Type MGS W-Beam and Spacer Blocks
 Install upgrade terminal sections
 Approach End: MASH Type A with Rubrail
 Trailing End: MASH Type A with Rubrail

± STA. 93+60± TO ± STA. 94+85± LT. (BASE BID)

Remove existing guardrail system and end treatments
 Install 50.0 LF Guardrail Type MGS W-Beam and Spacer Blocks
 Install upgrade terminal sections
 Approach End: Modified Type A-1 with Rubrail
 Trailing End: Trailing-End Anchor System

± STA. 97+70± TO ± STA. 103+45± LT. (BASE BID)

Remove existing guardrail system and end treatments
 Install 475.0 LF Guardrail Type MGS W-Beam and Spacer Blocks
 Install upgrade terminal sections
 Approach End: MASH Type A with Rubrail
 Trailing End: Modified Type A-1 with Rubrail

± CURVE DATA:
 $\Delta = 58^{\circ}32'00''$
 $\frac{\Delta}{2} = 29^{\circ}16'00''$
 $R = 573.14'$
 $T = 321.19'$
 $C = 560.39'$
 $Lc = 585.52'$
 $D.C. = 10^{\circ}00'00''$

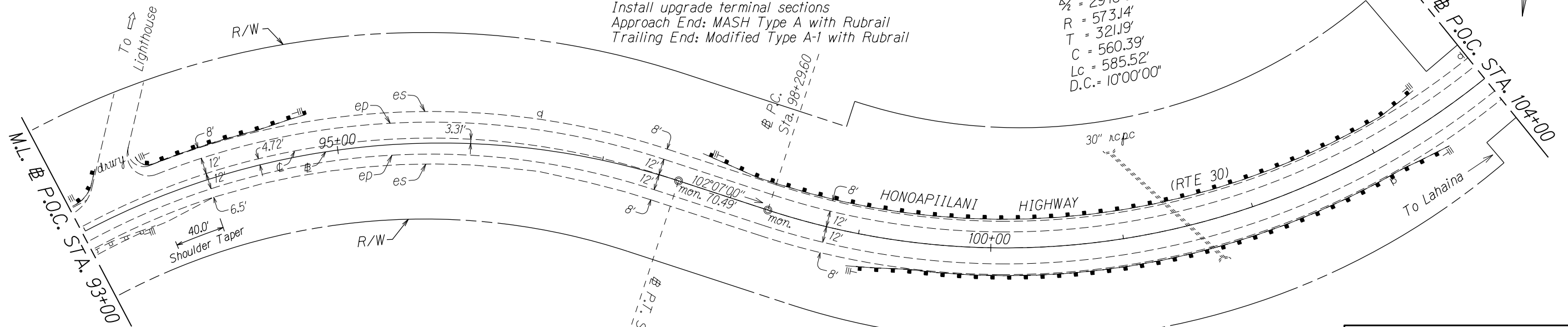

± STA. 98+95± TO ± STA. 103+45± RT. (BASE BID)

Remove existing guardrail system and end treatments
 Abandon post in place and stabilize slope (Sta. 101+00± to 102+00±)
 Install 100.0 LF Guardrail Type MGS W-Beam and Spacer Blocks with 8-Ft. post (Sta. 101+00± to 102+00±)
 Install 250.0 LF Guardrail Type MGS W-Beam and Spacer Blocks
 Install upgrade terminal sections
 Approach End: Modified Type A-1 with Rubrail
 Trailing End: MASH Type A with Rubrail

NOTE: Install New Type MGS standard 6-Ft. guardrail post or 8-Ft. guardrail post as required to adequately secure new guardrail system. Contractor shall abandon existing guardrail post in place as determined necessary to avoid damage to existing shoulder and/or slope area behind guardrail. Existing guardrail post to be abandoned in place shall be cut flush or below ground surface.

STATE OF HAWAII
 DEPARTMENT OF TRANSPORTATION
 HIGHWAYS DIVISION

ROADWAY PLANS
HONOAPIILANI HIGHWAY
GUARDRAIL & SHOULDER IMPROVEMENTS
 Vicinity of North Kihei Road to Hononana
 Federal-Aid Project No. STP-030-1(058)R

Scale: 1" = 40' Date: March, 2023

SHEET No. 2 OF 17 SHEETS

SURVEY PLOTTED BY	DATE
DRAWN BY	3/22
DESIGNED BY	
QUANTITIES BY	
CHECKED BY	

FED. ROAD DIST. NO.	STATE	FED. AID PROJ. NO.	FISCAL YEAR	SHEET NO.	TOTAL SHEETS
HAWAII	HAW.	STP-030-1(058)R	2023	23	40

NOTE: Install New Type MGS standard 6-Ft. guardrail post or 8-Ft. guardrail post as required to adequately secure new guardrail system. Contractor shall abandon existing guardrail post in place as determined necessary to avoid damage to existing shoulder and/or slope area behind guardrail. Existing guardrail post to be abandoned in place shall be cut flush or below ground surface.

§ STA. 105+95± TO § STA. 108+95± LT. (BASE BID)
 Remove existing guardrail system and end treatments
 Install 200.0 LF Guardrail Type MGS W-Beam and Spacer Blocks
 Install upgrade terminal sections
 Approach End: MASH Type A with Rubrail
 Trailing End: MASH Type A with Rubrail

§ STA. 371+75± TO § STA. 376+65± RT. (BASE BID)
 Remove existing guardrail system and end treatments
 Install 400.0 LF Guardrail Type MGS W-Beam and Spacer Blocks
 Install upgrade terminal sections
 Approach End: MFLT (TL-3)
 Trailing End: MASH Type A with Rubrail

§ STA. 365+15± TO § STA. 371+45± RT. (BASE BID)
 Remove existing guardrail system and end treatments
 Install 562.5 LF Guardrail Type MGS W-Beam and Spacer Blocks
 Install upgrade terminal sections
 Approach End: Modified Type A-1 with Rubrail
 Trailing End: Trailing-End Anchor System

§ STA. 355+95± TO § STA. 364+05± RT. (BASE BID)
 Remove existing guardrail system and end treatments
 Install 712.5 LF Guardrail Type MGS W-Beam and Spacer Blocks
 Install upgrade terminal sections
 Approach End: Modified Type A-1 with Rubrail
 Trailing End: Modified Type A-1 with Rubrail

§ STA. 363+20± TO § STA. 364+05± LT. (BASE BID)
 Remove existing guardrail system and end treatments
 Install upgrade terminal sections
 Approach End: Modified Type A-1 with Rubrail
 Trailing End: Modified Type A-1 with Rubrail

§ STA. 371+90± TO § STA. 375+75± LT. (BASE BID)
 Remove existing guardrail system and end treatments
 Install 300.0 LF Guardrail Type MGS W-Beam and Spacer Blocks
 Install upgrade terminal sections
 Approach End: MFLT (TL-3)
 Trailing End: MASH Type A with Rubrail

§ STA. 365+95± TO § STA. 367+55± LT. (BASE BID)
 Remove existing guardrail system and end treatments
 Install 62.5 LF Guardrail Type MGS W-Beam and Spacer Blocks
 Install upgrade terminal sections
 Approach End: Modified Type A-1 with Rubrail
 Trailing End: Modified Type A-1 with Rubrail

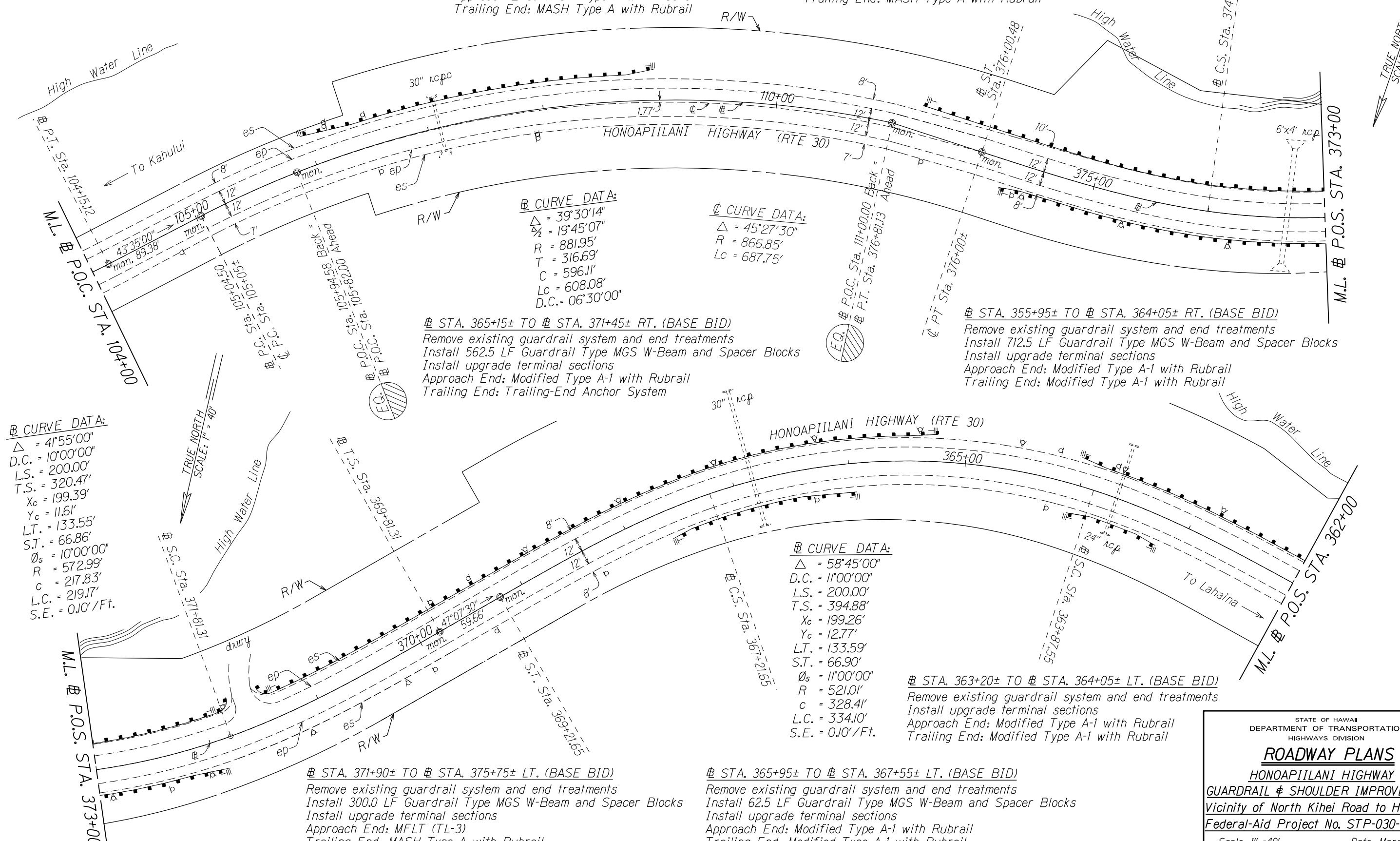

§ CURVE DATA:
 $\Delta = 41^{\circ}55'00''$
 $D.C. = 10^{\circ}00'00''$
 $L.S. = 200.00'$
 $T.S. = 320.47'$
 $X_c = 199.39'$
 $Y_c = 11.61'$
 $L.T. = 133.55'$
 $S.T. = 66.86'$
 $\phi_s = 10^{\circ}00'00''$
 $R = 572.99'$
 $c = 217.83'$
 $L.C. = 219.17'$
 $S.E. = 0.10' / Ft.$

§ CURVE DATA:
 $\Delta = 39^{\circ}30'14''$
 $\frac{\Delta}{2} = 19^{\circ}45'07''$
 $R = 881.95'$
 $T = 316.69'$
 $C = 596.11'$
 $L.C. = 608.08'$
 $D.C. = 06^{\circ}30'00''$

§ CURVE DATA:
 $\Delta = 45^{\circ}27'30''$
 $R = 866.85'$
 $L.C. = 687.75'$

§ CURVE DATA:
 $\Delta = 58^{\circ}45'00''$
 $D.C. = 11^{\circ}00'00''$
 $L.S. = 200.00'$
 $T.S. = 394.88'$
 $X_c = 199.26'$
 $Y_c = 12.77'$
 $L.T. = 133.59'$
 $S.T. = 66.90'$
 $\phi_s = 11^{\circ}00'00''$
 $R = 521.01'$
 $c = 328.41'$
 $L.C. = 334.10'$
 $S.E. = 0.10' / Ft.$

TRUE NORTH
 SCALE: 1" = 40'

SURVEY PLOTTED BY	DATE
DRAWN BY	3/23
DESIGNED BY	LH
QUANTITIES BY	me/jay
CHECKED BY	me/jay

STATE OF HAWAII
 DEPARTMENT OF TRANSPORTATION
 HIGHWAYS DIVISION

ROADWAY PLANS
HONOAPIILANI HIGHWAY
GUARDRAIL & SHOULDER IMPROVEMENTS
 Vicinity of North Kihei Road to Hononana
 Federal-Aid Project No. STP-030-1(058)R

Scale: 1" = 40' Date: March, 2023

SHEET No. 3 OF 17 SHEETS

FED. ROAD DIST. NO.	STATE	FED. AID PROJ. NO.	FISCAL YEAR	SHEET NO.	TOTAL SHEETS
HAWAII	HAW.	STP-030-1(058)R	2023	24	40

NOTE: Install New Type MGS standard 6-Ft. guardrail post or 8-Ft. guardrail post as required to adequately secure new guardrail system. Contractor shall abandon existing guardrail post in place as determined necessary to avoid damage to existing shoulder and/or slope area behind guardrail. Existing guardrail post to be abandoned in place shall be cut flush or below ground surface.

§ STA. 346+00± TO § STA. 352+10± RT. (BASE BID)
 Remove existing guardrail system and end treatments
 Install 312.5 LF Strong Post Thrie-Beam Guardrail (Sta. 347+25± to 350+37.5±)
 Transition Thrie-Beam Guardrail to Guardrail Type MGS (2 x 6.25 LF)
 Install 200.0 LF Guardrail Type MGS W-Beam and Spacer Blocks
 Install upgrade terminal sections
 Approach End: MFLT (TL-3)
 Trailing End: Modified Type A-1 with Rubrail

§ CURVE DATA:
 $\Delta = 26^{\circ}22'30''$
 D.C. = 7'00'00"
 L.S. = 200.00'
 T.S. = 292.23'
 $X_c = 199.70'$
 $Y_c = 8.14'$
 L.T. = 133.44'
 S.T. = 66.76'

$\phi_s = 7^{\circ}00'13''$
 $R = 819.10'$
 $c = 176.47'$
 $L.C. = 176.81'$
 $S.E. = 0.10' / Ft.$

§ STA. 334+40± TO § STA. 345+00± RT. (BASE BID)
 Remove existing guardrail system and end treatments
 Install 87.5 LF Strong Post Thrie-Beam Guardrail (Sta. 342+75± to 343+62.5±)
 Transition Thrie-Beam Guardrail to Guardrail Type MGS (2 x 6.25 LF)
 Install 887.5 LF Guardrail Type MGS W-Beam and Spacer Blocks
 Install upgrade terminal sections
 Approach End: Modified Type 1-A with Rubrail
 Trailing End: Trailing-End Anchor System

§ STA. 355+95± TO § STA. 360+05± LT. (BASE BID)
 Remove existing guardrail system and end treatments
 Install 312.5 LF Guardrail Type MGS W-Beam and Spacer Blocks
 Install upgrade terminal sections
 Approach End: Modified Type A-1 with Rubrail
 Trailing End: Modified Type A-1 with Rubrail

§ CURVE DATA:
 $\Delta = 10^{\circ}45'00''$ L.T. = 133.37'
 $D.C. = 4^{\circ}00'00''$ S.T. = 66.69'
 $L.S. = 200.00'$ $\phi_s = 1.43078^{\circ}$
 $T.S. = 234.87'$ $R = 68.76'$
 $X_c = 199.90'$ $c = 68.77'$
 $Y_c = 4.65'$ $S.E. = 0.06' / Ft.$

§ CURVE DATA:
 $\Delta = 60^{\circ}05'00''$
 $D.C. = 10^{\circ}00'00''$
 $L.S. = 200.00'$
 $T.S. = 432.93'$
 $X_c = 199.39'$
 $Y_c = 11.61'$
 $L.T. = 135.55'$
 $S.T. = 64.89'$
 $\phi_s = 10^{\circ}18'26''$
 $R = 581.51'$
 $c = 392.71'$
 $L.C. = 400.58'$
 $S.E. = 0.10' / Ft.$

§ STA. 347+50± TO § STA. 350+75± LT. (BASE BID)
 Remove existing guardrail system between anchor blocks
 Install 50.0 LF Strong Post Thrie-Beam Guardrail with 8' posts (Sta. 349+45± to 349+95±)
 Install 275.0 LF Strong Post Thrie-Beam Guardrail
 Install new terminal connectors (RTE01b)
 Attach to existing anchor blocks
 Repair anchor blocks as needed

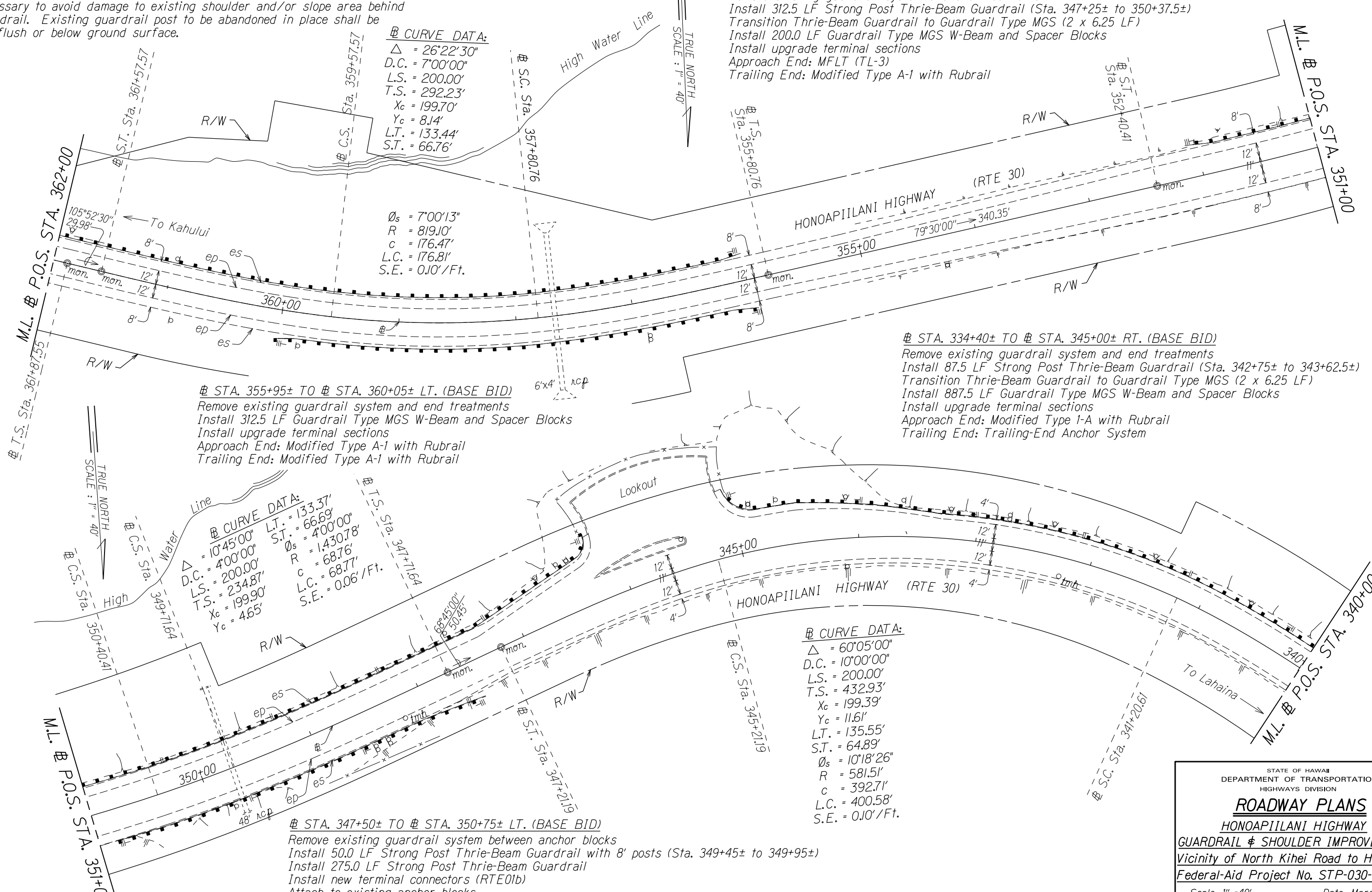

DATE	3/23
SURVEY PLOTTED BY	
DRAWN BY	LH
DESIGNED BY	me/jay
QUANTITIES BY	
CHECKED BY	

STATE OF HAWAII
 DEPARTMENT OF TRANSPORTATION
 HIGHWAYS DIVISION

ROADWAY PLANS
HONOAPIILANI HIGHWAY
GUARDRAIL & SHOULDER IMPROVEMENTS
 Vicinity of North Kihei Road to Hononana
 Federal-Aid Project No. STP-030-1(058)R

Scale: 1" = 40' Date: March, 2023

SHEET No. 4 OF 17 SHEETS

FED. ROAD DIST. NO.	STATE	FED. AID PROJ. NO.	FISCAL YEAR	SHEET NO.	TOTAL SHEETS
HAWAII	HAW.	STP-030-1(058)R	2023	25	40

NOTE: Install New Type MGS standard 6-Ft. guardrail post or 8-Ft. guardrail post as required to adequately secure new guardrail system. Contractor shall abandon existing guardrail post in place as determined necessary to avoid damage to existing shoulder and/or slope area behind guardrail. Existing guardrail post to be abandoned in place shall be cut flush or below ground surface.

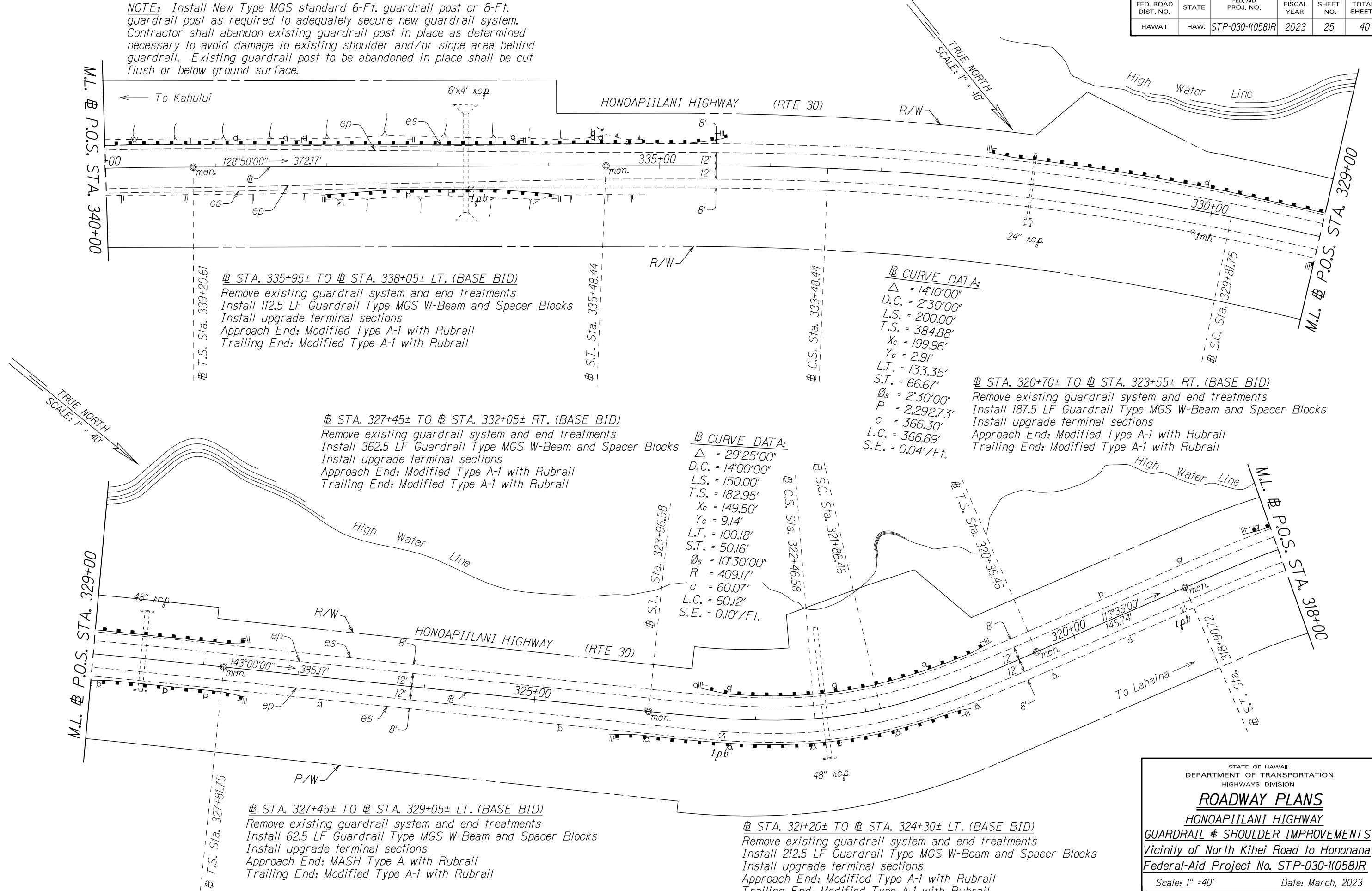

STA. 335+95± TO # STA. 338+05± LT. (BASE BID)
 Remove existing guardrail system and end treatments
 Install 112.5 LF Guardrail Type MGS W-Beam and Spacer Blocks
 Install upgrade terminal sections
 Approach End: Modified Type A-1 with Rubrail
 Trailing End: Modified Type A-1 with Rubrail

STA. 327+45± TO # STA. 332+05± RT. (BASE BID)
 Remove existing guardrail system and end treatments
 Install 362.5 LF Guardrail Type MGS W-Beam and Spacer Blocks
 Install upgrade terminal sections
 Approach End: Modified Type A-1 with Rubrail
 Trailing End: Modified Type A-1 with Rubrail

STA. 327+45± TO # STA. 329+05± LT. (BASE BID)
 Remove existing guardrail system and end treatments
 Install 62.5 LF Guardrail Type MGS W-Beam and Spacer Blocks
 Install upgrade terminal sections
 Approach End: MASH Type A with Rubrail
 Trailing End: Modified Type A-1 with Rubrail

CURVE DATA:
 Δ = 14°10'00"
 D.C. = 2°30'00"
 L.S. = 200.00'
 T.S. = 384.88'
 Xc = 199.96'
 Yc = 2.9'
 L.T. = 133.35'
 S.T. = 66.67'
 Øs = 2°30'00"
 R = 2,292.73'
 c = 366.30'
 L.C. = 366.69'
 S.E. = 0.04'/Ft.

CURVE DATA:
 Δ = 29°25'00"
 D.C. = 14°00'00"
 L.S. = 150.00'
 T.S. = 182.95'
 Xc = 149.50'
 Yc = 9.14'
 L.T. = 100.18'
 S.T. = 50.16'
 Øs = 10°30'00"
 R = 409.17'
 c = 60.07'
 L.C. = 60.12'
 S.E. = 0.10'/Ft.

STA. 320+70± TO # STA. 323+55± RT. (BASE BID)
 Remove existing guardrail system and end treatments
 Install 187.5 LF Guardrail Type MGS W-Beam and Spacer Blocks
 Install upgrade terminal sections
 Approach End: Modified Type A-1 with Rubrail
 Trailing End: Modified Type A-1 with Rubrail

STA. 321+20± TO # STA. 324+30± LT. (BASE BID)
 Remove existing guardrail system and end treatments
 Install 212.5 LF Guardrail Type MGS W-Beam and Spacer Blocks
 Install upgrade terminal sections
 Approach End: Modified Type A-1 with Rubrail
 Trailing End: Modified Type A-1 with Rubrail

SURVEY PLOTTED BY	DATE
DRAWN BY	3/23
DESIGNED BY	
NOTE BOOK	
QUANTITIES BY	
CHECKED BY	

STATE OF HAWAII
 DEPARTMENT OF TRANSPORTATION
 HIGHWAYS DIVISION

ROADWAY PLANS
HONOAPIILANI HIGHWAY
GUARDRAIL & SHOULDER IMPROVEMENTS
 Vicinity of North Kihei Road to Hononana
 Federal-Aid Project No. STP-030-1(058)R

Scale: 1" = 40' Date: March, 2023

SHEET No. 5 OF 17 SHEETS

FED. ROAD DIST. NO.	STATE	FED. AID PROJ. NO.	FISCAL YEAR	SHEET NO.	TOTAL SHEETS
HAWAII	HAW.	STP-030-1(058)R	2023	26	40

STA. 316+20± TO # STA. 318+30± RT. (BASE BID)

Remove existing guardrail system and end treatments
 Install 112.5 LF Guardrail Type MGS W-Beam and Spacer Blocks
 Install upgrade terminal sections
 Approach End: Modified Type A-1 with Rubrail
 Trailing End: Modified Type A-1 with Rubrail

CURVE DATA:

$\Delta = 61^{\circ}35'00''$
 D.C. = 14'00'00"
 L.S. = 150.00'
 T.S. = 320.17'
 Yc = 149.32'
 Yc = 9.14'
 L.T. = 100.18'
 S.T. = 50.16'
 $\phi_s = 10^{\circ}30'00''$
 R = 409.24'
 c = 283.86'
 L.C. = 289.89'
 S.E. = 0.10'/Ft.

STA. 309+20± TO # STA. 315+05± RT. (BASE BID)

Remove existing guardrail system and end treatments
 Abandon post in place and stabilize slope (Sta. 310+90± to 311+90±)
 Install 100.0 LF Guardrail Type MGS W-Beam and Spacer Blocks with 8' post (Sta. 310+90± to 311+90±)
 Install 387.5 LF Guardrail Type MGS W-Beam and Spacer Blocks
 Install upgrade terminal sections
 Approach End: Modified Type A-1 with Rubrail
 Trailing End: Modified Type A-1 with Rubrail

M.L. # P.O.S. STA. 318+00

M.L. # P.O.S. STA. 307+00

CURVE DATA:
 $\Delta = 31^{\circ}35'00''$
 D.C. = 14'00'00"
 L.S. = 150.00'
 T.S. = 191.31'
 Yc = 149.50'
 Yc = 9.14'
 L.T. = 100.18'
 S.T. = 50.16'
 $\phi_s = 10^{\circ}30'00''$
 R = 409.18'
 c = 75.49'
 L.C. = 75.60'
 S.E. = 0.10'/Ft.

STA. 309+45± TO # STA. 314+30± LT. (BASE BID)

Remove existing guardrail system and end treatments
 Install 387.5 LF Guardrail Type MGS W-Beam and Spacer Blocks
 Install upgrade terminal sections
 Approach End: Modified Type A-1 with Rubrail
 Trailing End: Modified Type A-1 with Rubrail

CURVE DATA:

$\Delta = 52^{\circ}30'00''$
 D.C. = 14'00'00"
 L.S. = 150.00'
 T.S. = 277.88'
 Yc = 149.50'
 Yc = 9.14'
 L.T. = 100.18'
 S.T. = 50.16'
 $\phi_s = 31^{\circ}30'00''$
 R = 409.26'
 c = 222.19'
 L.C. = 225.02'
 S.E. = 0.10'/Ft.

STA. 297+20± TO # STA. 300+30± RT. (BASE BID)

Remove existing guardrail system and end treatments
 Install 212.5 LF Guardrail Type MGS W-Beam and Spacer Blocks
 Install upgrade terminal sections
 Approach End: Modified Type A-1 with Rubrail
 Trailing End: Modified Type A-1 with Rubrail

STA. 303+70± TO # STA. 307+05± RT. (BASE BID)

Remove existing guardrail system and end treatments
 Install 237.5 LF Guardrail Type MGS W-Beam and Spacer Blocks
 Install upgrade terminal sections
 Approach End: Modified Type A-1 with Rubrail
 Trailing End: Modified Type A-1 with Rubrail

CURVE DATA:

$\Delta = 66^{\circ}25'00''$
 D.C. = 14'00'00"
 L.S. = 150.00'
 T.S. = 344.32'
 Yc = 149.32'
 Yc = 9.14'
 L.T. = 100.18'
 S.T. = 50.16'
 $\phi_s = 10^{\circ}30'00''$
 R = 409.26'
 c = 313.99'
 L.C. = 324.42'
 S.E. = 0.10'/Ft.

STA. 304+75± TO # STA. 306+30± LT. (BASE BID)

Remove existing guardrail system and end treatments
 Install 62.5 LF Guardrail Type MGS W-Beam and Spacer Blocks
 Install upgrade terminal sections
 Approach End: Modified Type A-1 with Rubrail
 Trailing End: Modified Type A-1 with Rubrail

STA. 298+45± TO # STA. 300+05± LT. (BASE BID)

Remove existing guardrail system and end treatments
 Install 62.5 LF Guardrail Type MGS W-Beam and Spacer Blocks
 Install upgrade terminal sections
 Approach End: Modified Type A-1 with Rubrail
 Trailing End: Modified Type A-1 with Rubrail

NOTE: Install New Type MGS standard 6-Ft. guardrail post or 8-Ft. guardrail post as required to adequately secure new guardrail system. Contractor shall abandon existing guardrail post in place as determined necessary to avoid damage to existing shoulder and/or slope area behind guardrail. Existing guardrail post to be abandoned in place shall be cut flush or below ground surface.

SURVEY PLOTTED BY	DATE
DRAWN BY	3/23
DESIGNED BY	
QUANTITIES BY	
CHECKED BY	
ORIGINAL PLAN	
NOTE BOOK	
me/jay	
mm/ab/gdn	

STATE OF HAWAII
 DEPARTMENT OF TRANSPORTATION
 HIGHWAYS DIVISION

ROADWAY PLANS
HONOAPIILANI HIGHWAY
GUARDRAIL & SHOULDER IMPROVEMENTS
 Vicinity of North Kihei Road to Hononana
 Federal-Aid Project No. STP-030-1(058)R

Scale: 1" = 40' Date: March, 2023
 SHEET No. 6 OF 17 SHEETS

FED. ROAD DIST. NO.	STATE	FED. AID PROJ. NO.	FISCAL YEAR	SHEET NO.	TOTAL SHEETS
HAWAII	HAW.	STP-030-1(058)R	2023	27	40

§ STA. 290+45± TO § STA. 295+55± RT. (BASE BID)
 Remove existing guardrail system and end treatments
 Install 412.5 LF Guardrail Type MGS W-Beam and Spacer Blocks
 Install upgrade terminal sections
 Approach End: MASH Type A with Rubrail
 Trailing End: Modified Type A-1 with Rubrail

§ STA. 286+45± TO § STA. 290+05± RT. (BASE BID)
 Remove existing guardrail system and end treatments
 Install 262.5 LF Guardrail Type MGS W-Beam and Spacer Blocks
 Install upgrade terminal sections
 Approach End: MASH Type A with Rubrail
 Trailing End: MASH Type A with Rubrail

§ CURVE DATA:

$\Delta = 57^{\circ}33'00''$
 D.C. = 14'00"00"
 L.S. = 150.00'
 T.S. = 300.94'
 Xc = 149.50'
 Yc = 9.14'
 L.T. = 100.18'
 S.T. = 50.16'
 $\phi_s = 10^{\circ}30'00''$
 R = 409.25'
 c = 256.68'
 L.C. = 261.08'
 S.E. = 0.10'/Ft.

§ CURVE DATA:

$\Delta = 66^{\circ}03'00''$
 D.C. = 14'00"00"
 L.S. = 150.00'
 T.S. = 342.44'
 Xc = 149.50'
 Yc = 9.14'
 L.T. = 100.18'
 S.T. = 50.16'
 $\phi_s = 10^{\circ}30'00''$
 R = 409.25'
 c = 313.57'
 L.C. = 321.80'
 S.E. = 0.10'/Ft.

§ STA. 286+95± TO § STA. 289+55± LT. (BASE BID)
 Remove existing guardrail system and end treatments
 Install 162.5 LF Guardrail Type MGS W-Beam and Spacer Blocks
 Install upgrade terminal sections
 Approach End: Modified Type A-1 with Rubrail
 Trailing End: Modified Type A-1 with Rubrail

§ STA. 279+85± TO § STA. 284+05± RT. (BASE BID)
 Remove existing guardrail system and end treatments
 Install 325.0 LF Guardrail Type MGS W-Beam and Spacer Blocks
 Install upgrade terminal sections
 Approach End: Modified Type A-1 with Rubrail
 Trailing End: MASH Type A with Rubrail

§ STA. 270+55± TO § STA. 277+80± RT. (BASE BID)
 Remove existing guardrail system and end treatments
 Install 625.0 LF Guardrail Type MGS W-Beam and Spacer Blocks
 Install upgrade terminal section
 Approach End: Modified Type A-1 with Rubrail
 Trailing End: Modified Type A-1 with Rubrail

§ STA. 279+95± TO § STA. 283+05± LT. (BASE BID)
 Remove existing guardrail system and end treatments
 Install 212.5 LF Guardrail Type MGS W-Beam and Spacer Blocks
 Install upgrade terminal sections
 Approach End: Modified Type A-1 with Rubrail
 Trailing End: Modified Type A-1 with Rubrail

§ CURVE DATA:

$\Delta = 2^{\circ}50'00''$
 $\frac{\Delta}{2} = 1^{\circ}25'00''$
 R = 5,729.58'
 T = 141.70'
 C = 283.30'
 Lc = 283.33'
 D.C. = 1'00"00"

NOTE: Install New Type MGS standard 6-Ft. guardrail post or 8-Ft. guardrail post as required to adequately secure new guardrail system. Contractor shall abandon existing guardrail post in place as determined necessary to avoid damage to existing shoulder and/or slope area behind guardrail. Existing guardrail post to be abandoned in place shall be cut flush or below ground surface.

SURVEY PLOTTED BY	DATE
DRAWN BY	3/23
DESIGNED BY	
QUANTITIES BY	
CHECKED BY	
ORIGINAL PLAN	
NOTE BOOK	
mei,jay	
mei,jay	
mei,jay	

STATE OF HAWAII
 DEPARTMENT OF TRANSPORTATION
 HIGHWAYS DIVISION

ROADWAY PLANS
HONOAPIILANI HIGHWAY
GUARDRAIL & SHOULDER IMPROVEMENTS
 Vicinity of North Kihei Road to Hononana
 Federal-Aid Project No. STP-030-1(058)R

Scale: 1" = 40' Date: March, 2023

SHEET No. 7 OF 17 SHEETS

FED. ROAD DIST. NO.	STATE	FED. AID PROJ. NO.	FISCAL YEAR	SHEET NO.	TOTAL SHEETS
HAWAII	HAW.	STP-030-1(058)R	2023	28	40

NOTE: Install New Type MGS standard 6-Ft. guardrail post or 8-Ft. guardrail post as required to adequately secure new guardrail system. Contractor shall abandon existing guardrail post in place as determined necessary to avoid damage to existing shoulder and/or slope area behind guardrail. Existing guardrail post to be abandoned in place shall be cut flush or below ground surface.

STA. 261+45± TO # STA. 265+55± RT. (BASE BID)
 Remove existing guardrail system and end treatments
 Install 312.5 LF Guardrail Type MGS W-Beam and Spacer Blocks
 Install upgrade terminal sections
 Approach End: MASH Type A with Rubrail
 Trailing End: Modified Type A-1 with Rubrail

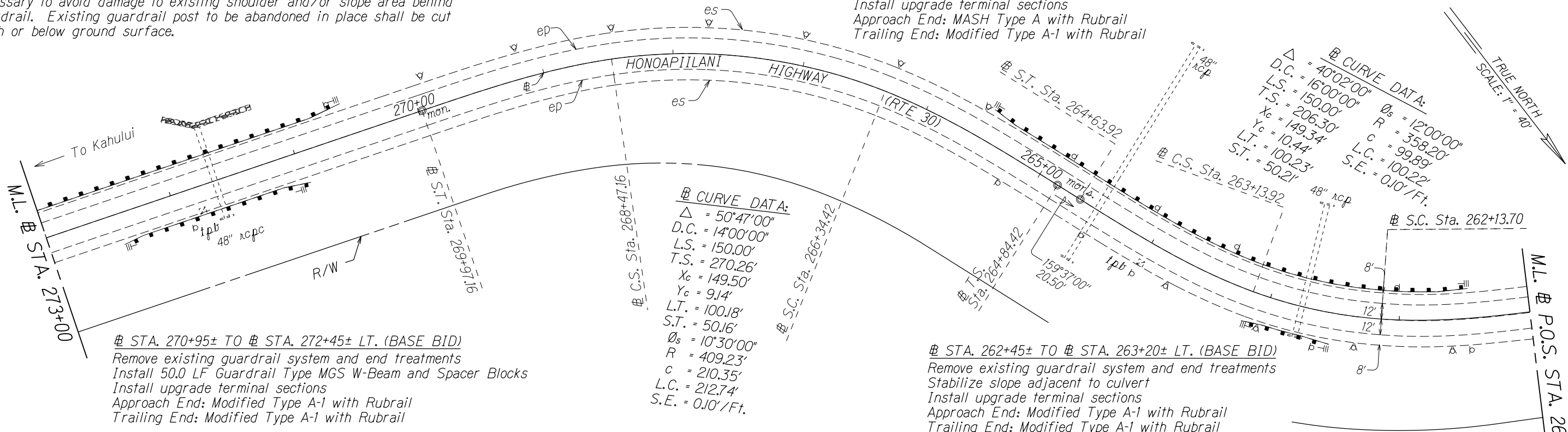

STA. 270+95± TO # STA. 272+45± LT. (BASE BID)
 Remove existing guardrail system and end treatments
 Install 50.0 LF Guardrail Type MGS W-Beam and Spacer Blocks
 Install upgrade terminal sections
 Approach End: Modified Type A-1 with Rubrail
 Trailing End: Modified Type A-1 with Rubrail

CURVE DATA:
 $\Delta = 50^{\circ}47'00''$
 $D.C. = 14^{\circ}00'00''$
 $L.S. = 150.00'$
 $T.S. = 270.26'$
 $X_c = 149.50'$
 $Y_c = 9.14'$
 $L.T. = 100.18'$
 $S.T. = 50.16'$
 $\phi_s = 10^{\circ}30'00''$
 $R = 409.23'$
 $c = 210.35'$
 $L.C. = 212.74'$
 $S.E. = 0.10'/Ft.$

CURVE DATA:
 $\Delta = 40^{\circ}02'00''$
 $D.C. = 16^{\circ}00'00''$
 $L.S. = 150.00'$
 $T.S. = 206.30'$
 $X_c = 149.34'$
 $Y_c = 10.44'$
 $L.T. = 100.23'$
 $S.T. = 50.21'$
 $\phi_s = 12^{\circ}00'00''$
 $R = 358.20'$
 $c = 99.89'$
 $L.C. = 100.22'$
 $S.E. = 0.10'/Ft.$

STA. 262+45± TO # STA. 263+20± LT. (BASE BID)
 Remove existing guardrail system and end treatments
 Stabilize slope adjacent to culvert
 Install upgrade terminal sections
 Approach End: Modified Type A-1 with Rubrail
 Trailing End: Modified Type A-1 with Rubrail

STA. 251+85± TO # STA. 255+12± RT. (BASE BID)
 Remove existing guardrail system and approach end treatment
 Existing trailing end treatment to remain
 Install 237.5 LF Guardrail Type MGS W-Beam and Spacer Blocks, and Type MGS transition (25 LF Each) to trailing end treatment
 Install upgrade terminal section
 Approach End: Modified Type A-1 with Rubrail

CURVE DATA:
 $\Delta = 17^{\circ}07'00''$
 $D.C. = 6^{\circ}00'00''$
 $L.S. = 150.00'$
 $T.S. = 218.85'$
 $X_c = 149.91'$
 $Y_c = 3.93'$
 $L.T. = 100.03'$
 $S.T. = 50.03'$
 $\phi_s = 4^{\circ}30'18''$
 $R = 956.17'$
 $c = 135.17'$
 $L.C. = 135.29'$
 $S.E. = 0.06'/Ft.$

STA. 258+30± TO # STA. 259+90± LT. (BASE BID)
 Remove existing guardrail system and approach end treatment
 Existing trailing end treatment to remain
 Install 75.0 LF Guardrail Type MGS W-Beam and Spacer Blocks, and Type MGS transition (25 LF Each) to trailing end treatment
 Install upgrade terminal section
 Approach End: Modified Type A-1 with Rubrail

STA. 253+95± TO # STA. 255+12± LT. (BASE BID)
 Remove existing guardrail system and trailing end treatment
 Existing approach end treatment to remain
 Install 25.0 LF Guardrail Type MGS W-Beam and Spacer Blocks, and Type MGS transition (25 LF Each) to approach end treatment
 Install upgrade terminal section
 Trailing End: Modified Type A-1 with Rubrail

SURVEY PLOTTED BY	DATE
DRAWN BY	3/23
DESIGNED BY	
QUANTITIES BY	
CHECKED BY	
ORIGINAL PLAN	
NOTE BOOK	
mei,jay	
mei,jay	
mei,jay	

STATE OF HAWAII
 DEPARTMENT OF TRANSPORTATION
 HIGHWAYS DIVISION

ROADWAY PLANS
HONOAPIILANI HIGHWAY
GUARDRAIL & SHOULDER IMPROVEMENTS
 Vicinity of North Kihei Road to Hononana
 Federal-Aid Project No. STP-030-1(058)R

Scale: 1" = 40' Date: March, 2023

SHEET No. 8 OF 17 SHEETS

@ STA. 244+80± TO @ STA. 247+05± RT. (BASE BID)
 Install 125.0 LF Guardrail Type MGS W-Beam and Spacer Blocks
 Install terminal sections
 Approach End: Modified Type A-1 with Rubrail
 Trailing End: Modified Type A-1 with Rubrail

CURVE DATA:
 $\Delta = 40^{\circ}28'30''$
 $D.C. = 13^{\circ}00'00''$
 $L.S. = 150.00'$
 $T.S. = 238.21'$
 $X_c = 149.57'$
 $Y_c = 8.49'$
 $L.T. = 100.15'$
 $S.T. = 50.14'$
 $\phi_s = 9^{\circ}44'52''$
 $R = 440.69'$
 $c = 160.46'$
 $L.C. = 161.36'$
 $S.E. = 0.10'/Ft.$

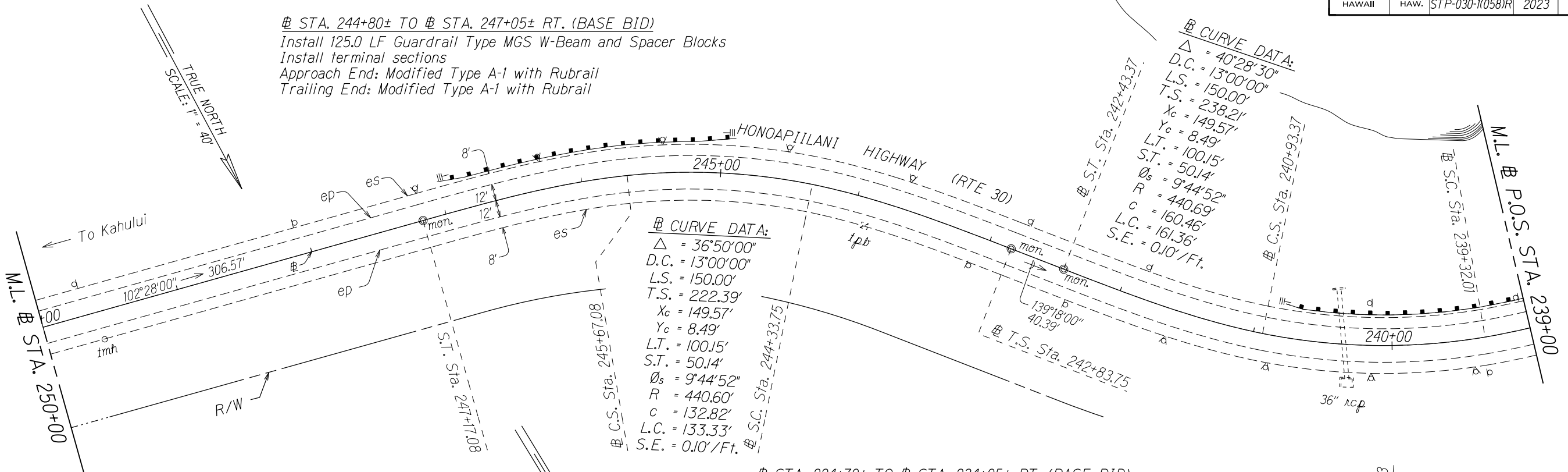

CURVE DATA:
 $\Delta = 36^{\circ}50'00''$
 $D.C. = 13^{\circ}00'00''$
 $L.S. = 150.00'$
 $T.S. = 222.39'$
 $X_c = 149.57'$
 $Y_c = 8.49'$
 $L.T. = 100.15'$
 $S.T. = 50.14'$
 $\phi_s = 9^{\circ}44'52''$
 $R = 440.69'$
 $c = 132.82'$
 $L.C. = 133.33'$
 $S.E. = 0.10'/Ft.$

@ STA. 224+70± TO @ STA. 234+05± RT. (BASE BID)
 Remove existing guardrail system and end treatments
 Install 837.5 LF Guardrail Type MGS W-Beam and Spacer Blocks
 Install upgrade terminal section
 Approach End: MSKT-SP-MGS8 (TL-3)
 Trailing End: Modified Type A-1 with Rubrail

@ STA. 235+85± TO @ STA. 240+85± RT. (BASE BID)
 Remove existing guardrail system and end treatments
 Install 400.0 LF Guardrail Type MGS W-Beam and Spacer Blocks
 Install upgrade terminal sections
 Approach End: Modified Type A-1 with Rubrail
 Trailing End: Modified Type A-1 with Rubrail

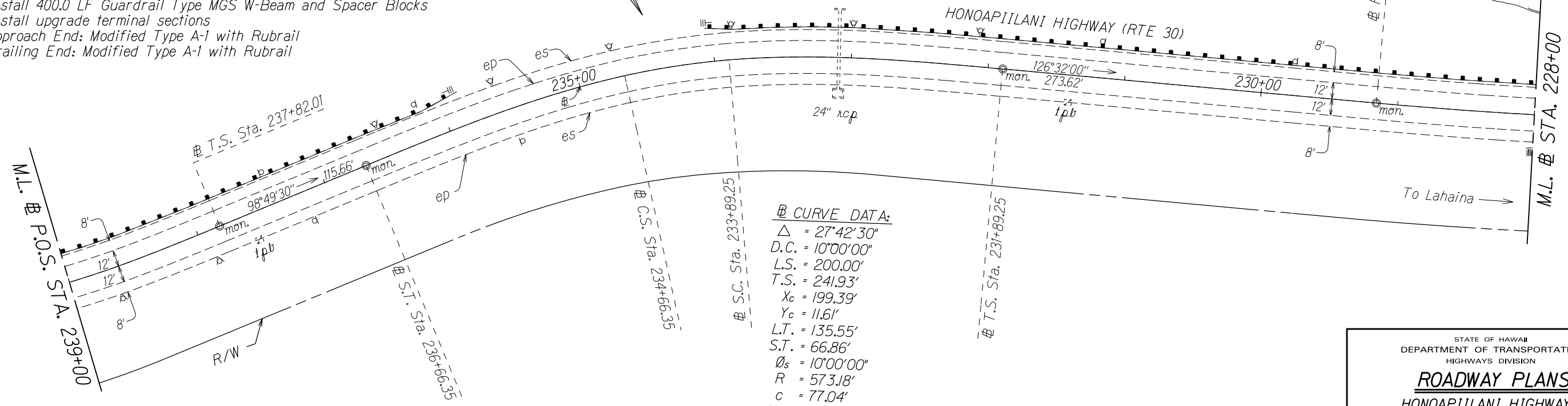

CURVE DATA:
 $\Delta = 27^{\circ}42'30''$
 $D.C. = 10^{\circ}00'00''$
 $L.S. = 200.00'$
 $T.S. = 241.93'$
 $X_c = 199.39'$
 $Y_c = 11.61'$
 $L.T. = 135.55'$
 $S.T. = 66.86'$
 $\phi_s = 10^{\circ}00'00''$
 $R = 573.18'$
 $c = 77.04'$
 $L.C. = 77.10'$
 $S.E. = 0.10'/Ft.$

NOTE: Install New Type MGS standard 6-Ft. guardrail post or 8-Ft. guardrail post as required to adequately secure new guardrail system. Contractor shall abandon existing guardrail post in place as determined necessary to avoid damage to existing shoulder and/or slope area behind guardrail. Existing guardrail post in place shall be cut flush or below ground surface.

STATE OF HAWAII
 DEPARTMENT OF TRANSPORTATION
 HIGHWAYS DIVISION
ROADWAY PLANS
HONOAPIILANI HIGHWAY
GUARDRAIL & SHOULDER IMPROVEMENTS
 Vicinity of North Kihei Road to Hononana
 Federal-Aid Project No. STP-030-1(058)R
 Scale: 1" = 40' Date: March, 2023
 SHEET No. 9 OF 17 SHEETS

SURVEY PLOTTED BY	DATE
DRAWN BY	3/23
DESIGNED BY	LH
QUANTITIES BY	
CHECKED BY	
ORIGINAL PLAN	
NOTE BOOK	
me/jay	
me/ajay	
me/ajay	

FED. ROAD DIST. NO.	STATE	FED. AID PROJ. NO.	FISCAL YEAR	SHEET NO.	TOTAL SHEETS
HAWAII	HAW.	STP-030-1(058)R	2023	30	40

END WORKSITE NO. 1
 Fed. Aid Proj. No. STP-030-1(058)R
 # Sta. 224+50 (BASE BID)

TRUE NORTH
 SCALE: 1" = 40'

CURVE DATA:
 $\Delta = 2^{\circ}50'00''$
 $\frac{\Delta}{2} = 1^{\circ}25'00''$
 $R = 5,729.58'$
 $T = 141.70'$
 $C = 283.30'$
 $Lc = 283.33'$
 $D.C. = 1^{\circ}00'00''$

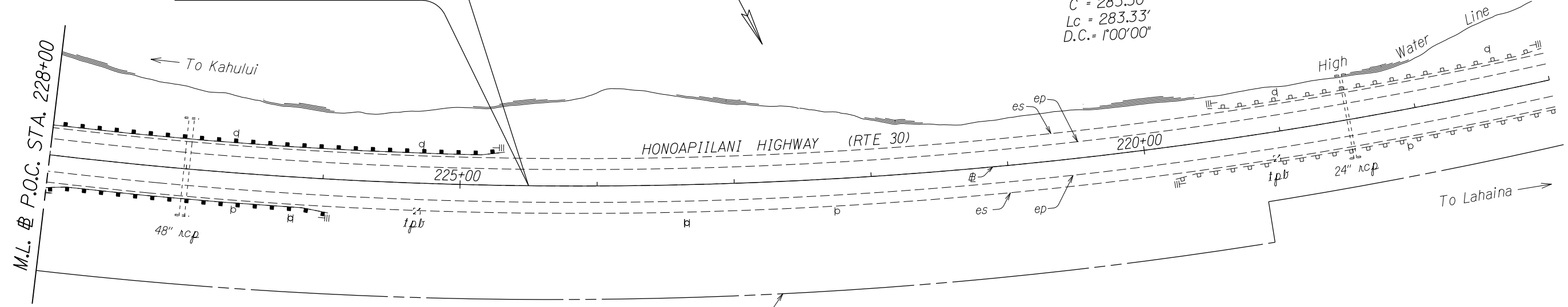

STA. 225+85± TO # STA. 228+10± LT. (BASE BID)
 Remove existing guardrail system and end treatments
 Install 125.0 LF Guardrail Type MGS W-Beam and Spacer Blocks
 Install upgrade terminal sections
 Approach End: MSKT-SP-MGS8 (TL-3)
 Trailing End: Modified Type A-1 with Rubrail

ORIGINAL PLAN	DATE
SURVEY PLOTTED BY	3/23
DRAWN BY	
DESIGNED BY	
QUANTITIES BY	
CHECKED BY	

NOTE: Install New Type MGS standard 6-Ft. guardrail post or 8-Ft. guardrail post as required to adequately secure new guardrail system. Contractor shall abandon existing guardrail post in place as determined necessary to avoid damage to existing shoulder and/or slope area behind guardrail. Existing guardrail post to be abandoned in place shall be cut flush or below ground surface.

STATE OF HAWAII
 DEPARTMENT OF TRANSPORTATION
 HIGHWAYS DIVISION

ROADWAY PLANS

HONOAPIILANI HIGHWAY
GUARDRAIL & SHOULDER IMPROVEMENTS
 Vicinity of North Kihei Road to Hononana
 Federal-Aid Project No. STP-030-1(058)R

Scale: 1" = 40' Date: March, 2023

SHEET No. 10 OF 17 SHEETS

FED. ROAD DIST. NO.	STATE	FED. AID PROJ. NO.	FISCAL YEAR	SHEET NO.	TOTAL SHEETS
HAWAII	HAW.	STP-030-1(058)R	2023	31	40

@ STA. 78+00± TO @ STA. 86+60± LT. (ADD. ALT. #1)
 Remove existing guardrail system and approach end treatment
 Install 800.0 LF Guardrail Type MGS W-Beam
 and Spacer Blocks, and Type MGS
 Transition (25 LF Each) to exist. guardrail
 Install upgrade terminal section
 Approach End: MFLT (TL-3)

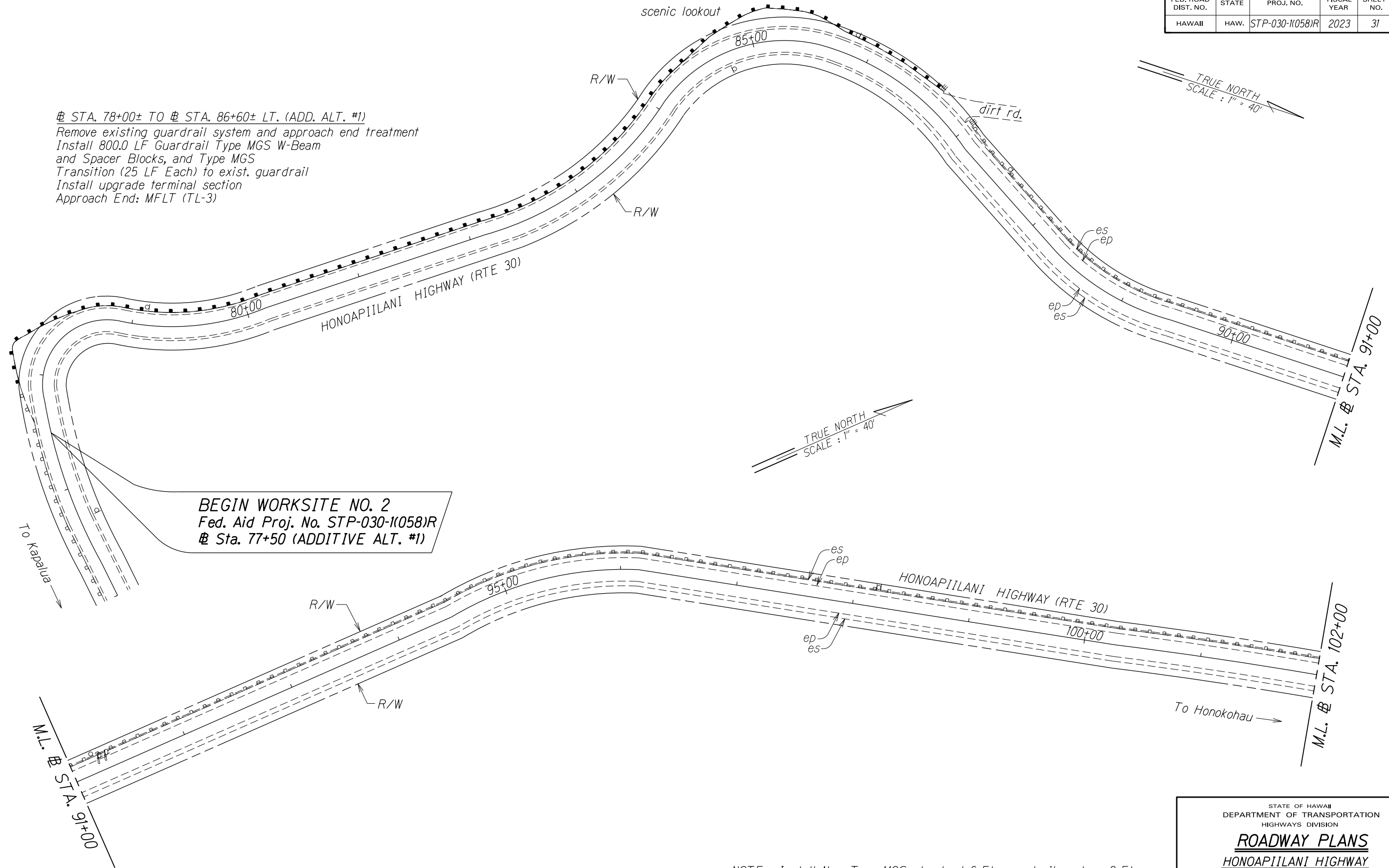

BEGIN WORKSITE NO. 2
 Fed. Aid Proj. No. STP-030-1(058)R
 @ Sta. 77+50 (ADDITIVE ALT. #1)

NOTE: Install New Type MGS standard 6-Ft. guardrail post or 8-Ft. guardrail post as required to adequately secure new guardrail system. Contractor shall abandon existing guardrail post in place as determined necessary to avoid damage to existing shoulder and/or slope area behind guardrail. Existing guardrail post to be abandoned in place shall be cut flush or below ground surface.

SURVEY PLOTTED BY	DATE
DRAWN BY	3/23
DESIGNED BY	
QUANTITIES BY	
CHECKED BY	
ORIGINAL PLAN	
NOTE BOOK	
me:lay	
me:lay	
me:lay	

STATE OF HAWAII
 DEPARTMENT OF TRANSPORTATION
 HIGHWAYS DIVISION
ROADWAY PLANS
HONOAPIILANI HIGHWAY
GUARDRAIL & SHOULDER IMPROVEMENTS
 Vicinity of North Kihei Road to Hononana
 Federal-Aid Project No. STP-030-1(058)R
 Scale: 1" = 40' Date: March, 2023
 SHEET No. 11 OF 17 SHEETS

FED. ROAD DIST. NO.	STATE	FED. AID PROJ. NO.	FISCAL YEAR	SHEET NO.	TOTAL SHEETS
HAWAII	HAW.	STP-030-1(058)R	2023	32	40

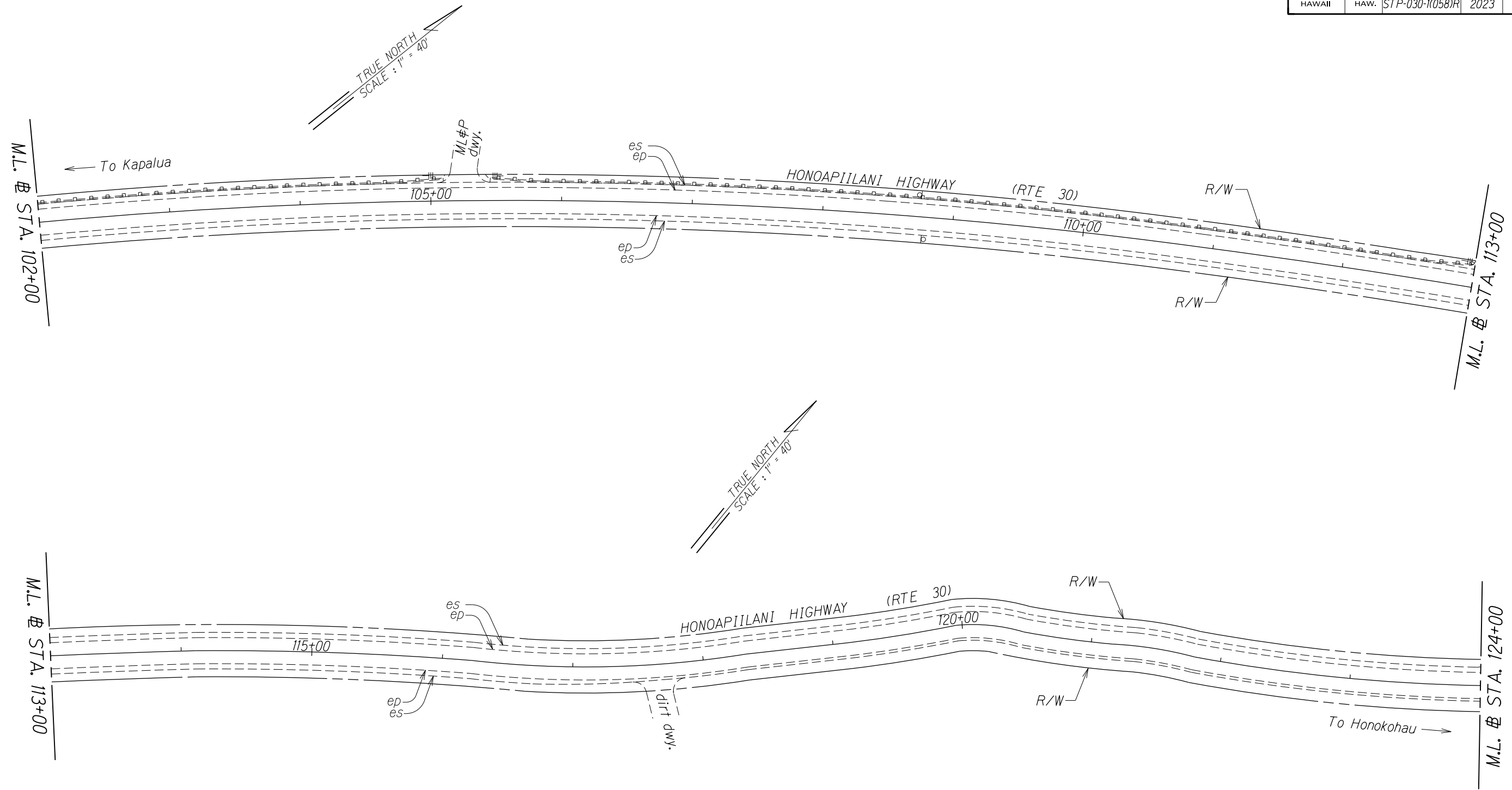

ORIGINAL PLAN	SURVEY PLOTTED BY	DATE
NOTE BOOK	DRAWN BY	3/23
me,lay	DESIGNED BY	
me,lay	QUANTITIES BY	
me,lay	CHECKED BY	

STATE OF HAWAII
DEPARTMENT OF TRANSPORTATION
HIGHWAYS DIVISION

ROADWAY PLANS

HONOAPIILANI HIGHWAY
GUARDRAIL & SHOULDER IMPROVEMENTS
Vicinity of North Kihei Road to Hononana
Federal-Aid Project No. STP-030-1(058)R

Scale: 1" = 40' Date: March, 2023

SHEET No. 12 OF 17 SHEETS

FED. ROAD DIST. NO.	STATE	FED. AID PROJ. NO.	FISCAL YEAR	SHEET NO.	TOTAL SHEETS
HAWAII	HAW.	STP-030-1(058)R	2023	33	40

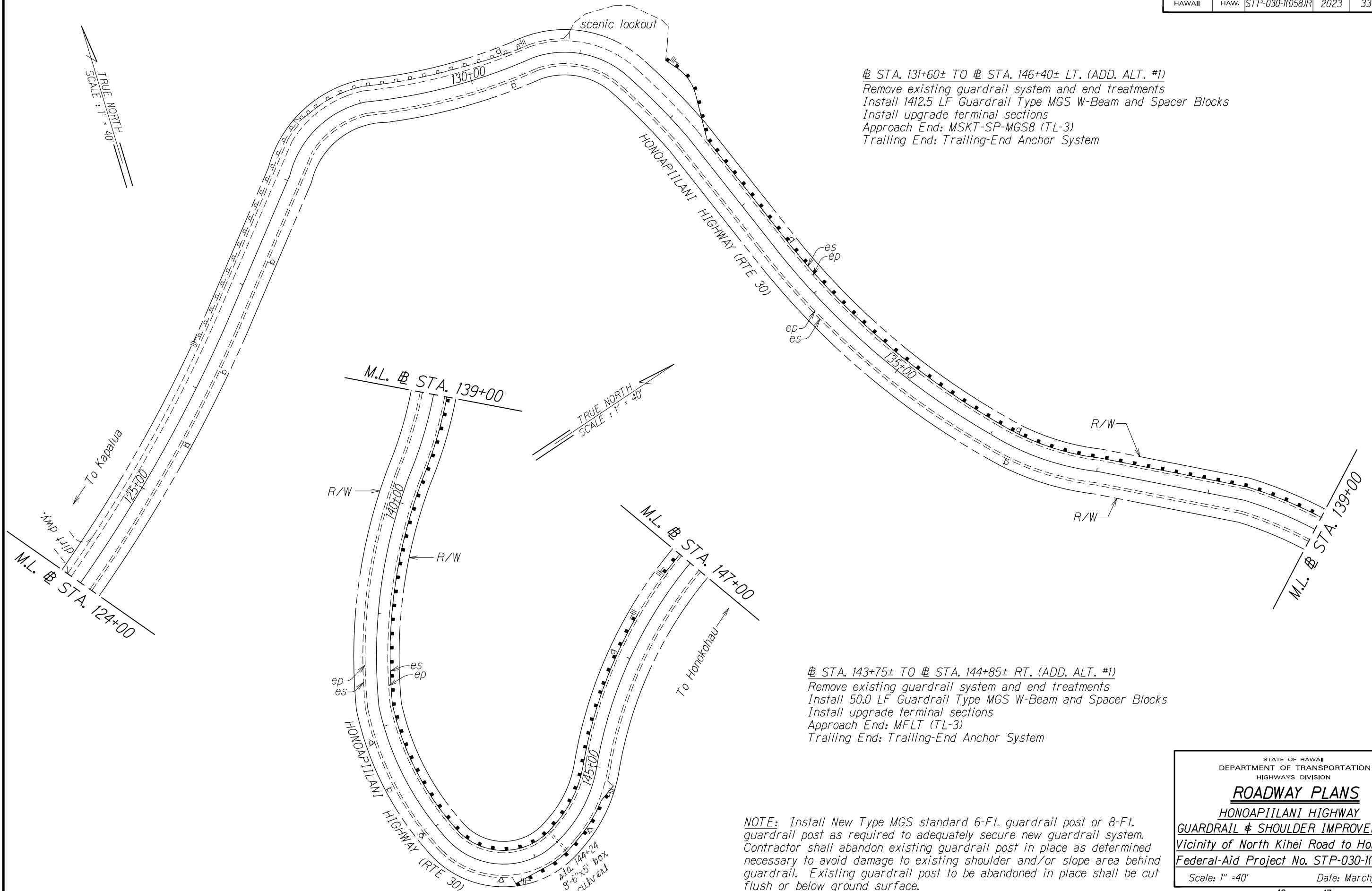

@ STA. 131+60± TO @ STA. 146+40± LT. (ADD. ALT. #1)
 Remove existing guardrail system and end treatments
 Install 1412.5 LF Guardrail Type MGS W-Beam and Spacer Blocks
 Install upgrade terminal sections
 Approach End: MSKT-SP-MGS8 (TL-3)
 Trailing End: Trailing-End Anchor System

@ STA. 143+75± TO @ STA. 144+85± RT. (ADD. ALT. #1)
 Remove existing guardrail system and end treatments
 Install 50.0 LF Guardrail Type MGS W-Beam and Spacer Blocks
 Install upgrade terminal sections
 Approach End: MFLT (TL-3)
 Trailing End: Trailing-End Anchor System

NOTE: Install New Type MGS standard 6-Ft. guardrail post or 8-Ft. guardrail post as required to adequately secure new guardrail system. Contractor shall abandon existing guardrail post in place as determined necessary to avoid damage to existing shoulder and/or slope area behind guardrail. Existing guardrail post to be abandoned in place shall be cut flush or below ground surface.

TRUE NORTH
 SCALE : 1" = 40'

TRUE NORTH
 SCALE : 1" = 40'

SURVEY PLOTTED BY	DATE
DRAWN BY	3/23
DESIGNED BY	
QUANTITIES BY	
CHECKED BY	

STATE OF HAWAII
 DEPARTMENT OF TRANSPORTATION
 HIGHWAYS DIVISION
ROADWAY PLANS
HONOPIILANI HIGHWAY
GUARDRAIL & SHOULDER IMPROVEMENTS
 Vicinity of North Kihei Road to Hononana
 Federal-Aid Project No. STP-030-1(058)R
 Scale: 1" = 40' Date: March, 2023
 SHEET No. 13 OF 17 SHEETS

FED. ROAD DIST. NO.	STATE	FED. AID PROJ. NO.	FISCAL YEAR	SHEET NO.	TOTAL SHEETS
HAWAII	HAW.	STP-030-1(058)R	2023	34	40

± STA. 146+80± TO ± STA. 154+50± LT. (ADD. ALT. #1)

Remove existing guardrail system and end treatments
 Install 712.50 LF Guardrail Type MGS W-Beam and Spacer Blocks
 Install upgrade terminal sections
 Approach End: MFLT (TL-3)
 Trailing End: Trailing-End Anchor System

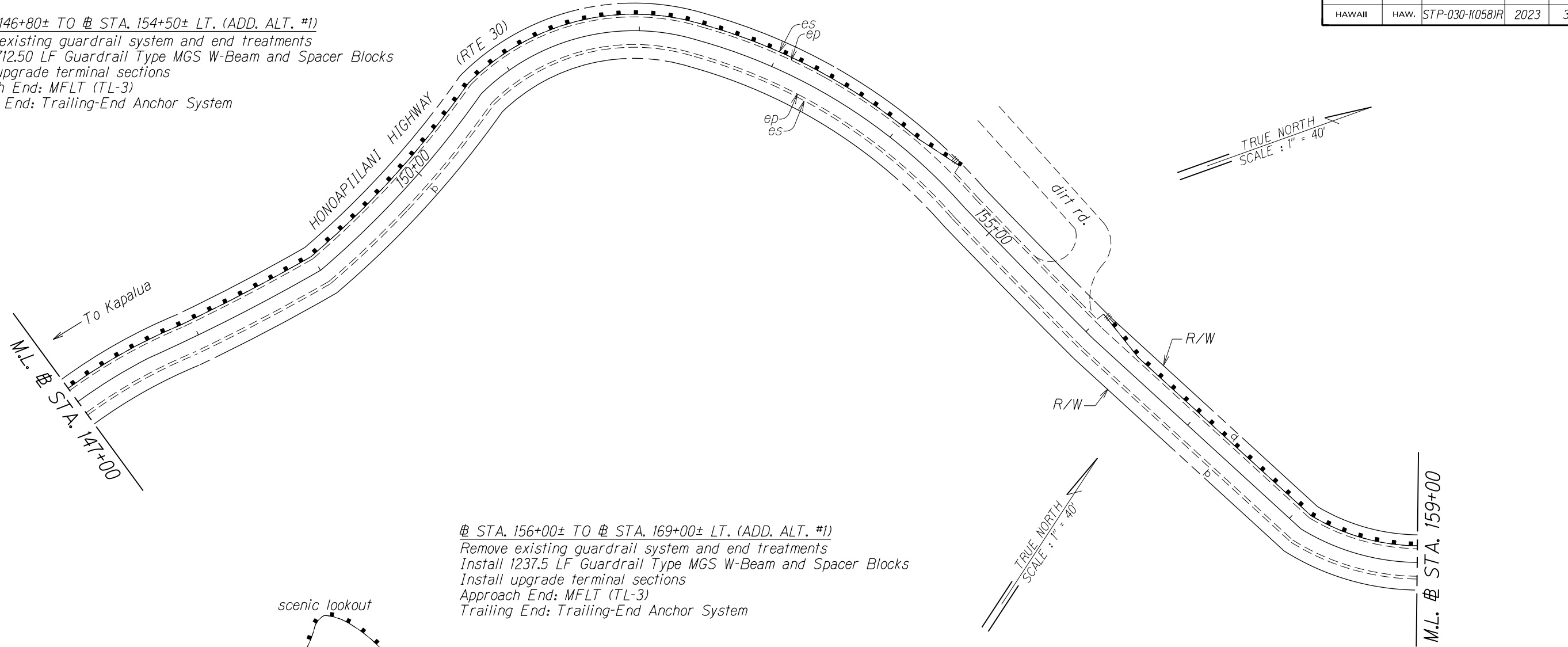

± STA. 156+00± TO ± STA. 169+00± LT. (ADD. ALT. #1)

Remove existing guardrail system and end treatments
 Install 1237.5 LF Guardrail Type MGS W-Beam and Spacer Blocks
 Install upgrade terminal sections
 Approach End: MFLT (TL-3)
 Trailing End: Trailing-End Anchor System

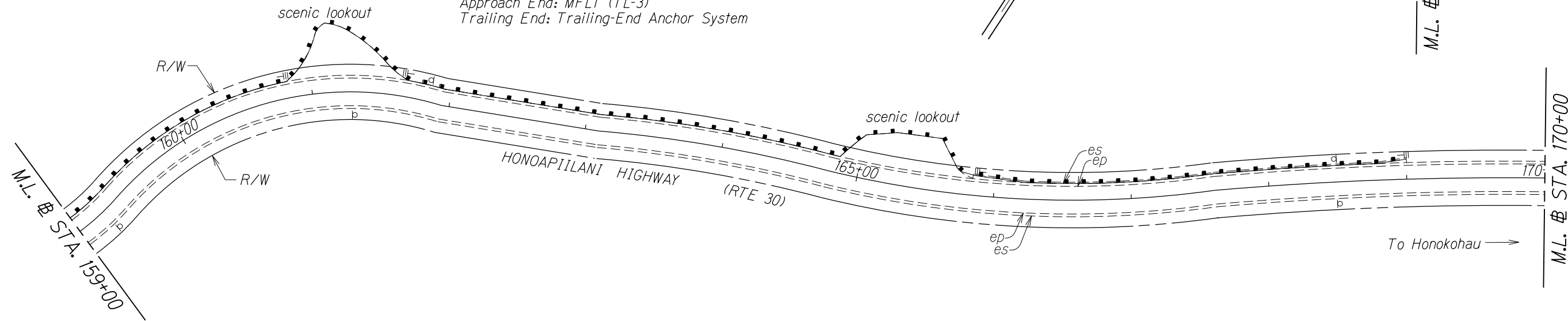

SURVEY PLOTTED BY	DATE
DRAWN BY	3/23
DESIGNED BY	
QUANTITIES BY	
CHECKED BY	

NOTE: Install New Type MGS standard 6-Ft. guardrail post or 8-Ft. guardrail post as required to adequately secure new guardrail system. Contractor shall abandon existing guardrail post in place as determined necessary to avoid damage to existing shoulder and/or slope area behind guardrail. Existing guardrail post to be abandoned in place shall be cut flush or below ground surface.

STATE OF HAWAII
 DEPARTMENT OF TRANSPORTATION
 HIGHWAYS DIVISION

ROADWAY PLANS

HONOAPIILANI HIGHWAY
GUARDRAIL & SHOULDER IMPROVEMENTS
 Vicinity of North Kihei Road to Hononana
 Federal-Aid Project No. STP-030-1(058)R

Scale: 1" = 40' Date: March, 2023

SHEET No. 14 OF 17 SHEETS

FED. ROAD DIST. NO.	STATE	FED. AID PROJ. NO.	FISCAL YEAR	SHEET NO.	TOTAL SHEETS
HAWAII	HAW.	STP-030-1(058)R	2023	35	40

M.L. # STA. 170+00

← To Kapalua

HONOAPIILANI HIGHWAY (RTE 30)

STA. 176+50± TO # STA. 181+00± LT. (ADD. ALT. #1)
 Remove existing guardrail system and end treatments
 Install 375.0 LF Guardrail Type MGS W-Beam and Spacer Blocks
 Install upgrade terminal sections
 Approach End: MSKT-SP-MGS8 (TL-3)
 Trailing End: Trailing-End Anchor System

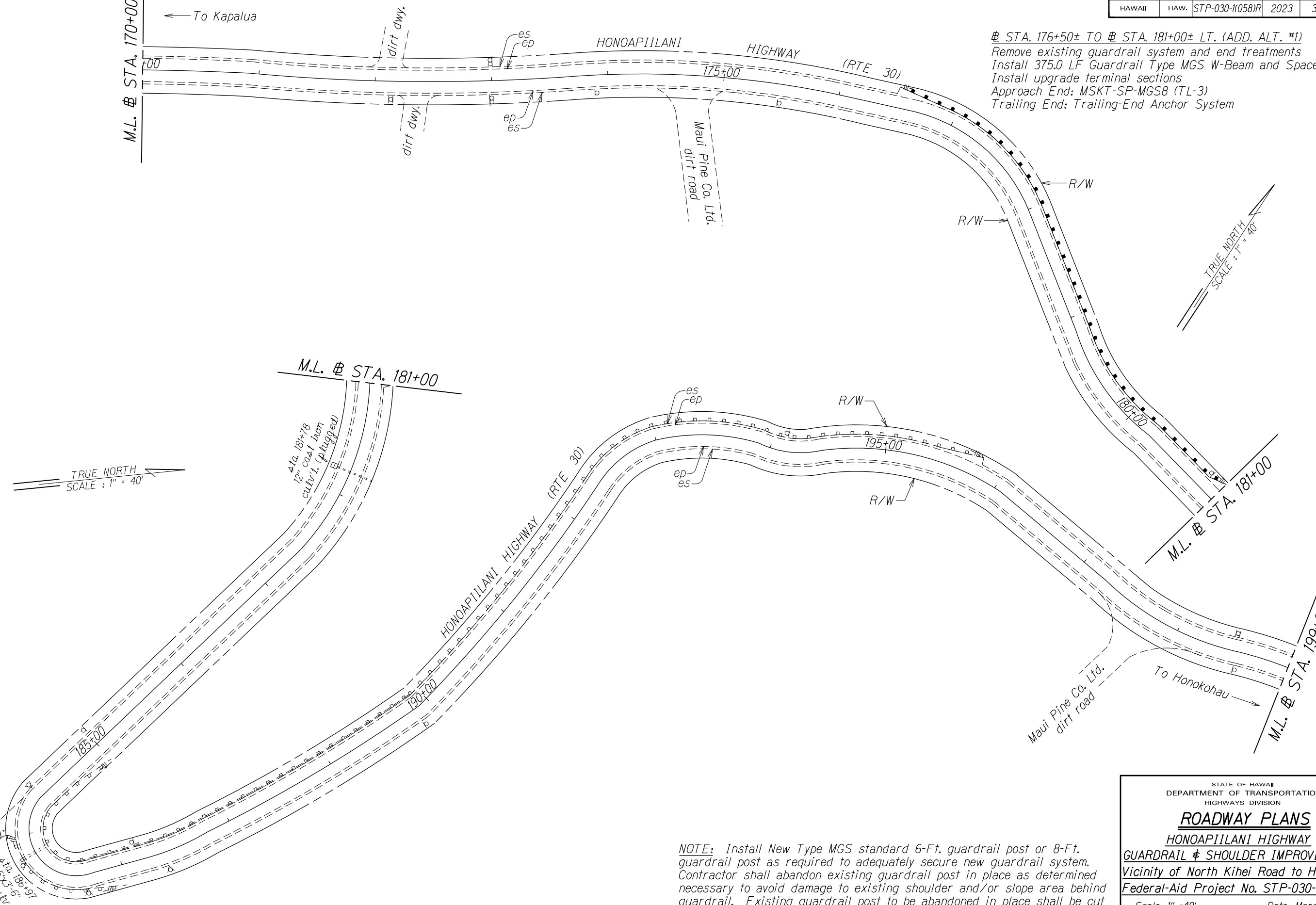

TRUE NORTH
SCALE: 1" = 40'

TRUE NORTH
SCALE: 1" = 40'

ORIGINAL PLAN	DATE
SURVEY PLOTTED BY	3/23
DRAWN BY	
DESIGNED BY	
QUANTITIES BY	
CHECKED BY	

NOTE: Install New Type MGS standard 6-Ft. guardrail post or 8-Ft. guardrail post as required to adequately secure new guardrail system. Contractor shall abandon existing guardrail post in place as determined necessary to avoid damage to existing shoulder and/or slope area behind guardrail. Existing guardrail post to be abandoned in place shall be cut flush or below ground surface.

STATE OF HAWAII
 DEPARTMENT OF TRANSPORTATION
 HIGHWAYS DIVISION

ROADWAY PLANS
HONOAPIILANI HIGHWAY
GUARDRAIL & SHOULDER IMPROVEMENTS
 Vicinity of North Kihei Road to Hononana
 Federal-Aid Project No. STP-030-1(058)R

Scale: 1" = 40' Date: March, 2023

SHEET No. 15 OF 17 SHEETS

FED. ROAD DIST. NO.	STATE	FED. AID PROJ. NO.	FISCAL YEAR	SHEET NO.	TOTAL SHEETS
HAWAII	HAW.	STP-030-1(058)R	2023	36	40

@ STA. 200+50± TO @ STA. 234+50± LT. (ADD. ALT. #1)
 Remove existing guardrail system and end treatments
 Install 3337.5 LF Guardrail Type MGS W-Beam and Spacer Blocks
 Install upgrade terminal sections
 Approach End: MFLT (TL-3)
 Trailing End: Trailing-End Anchor System

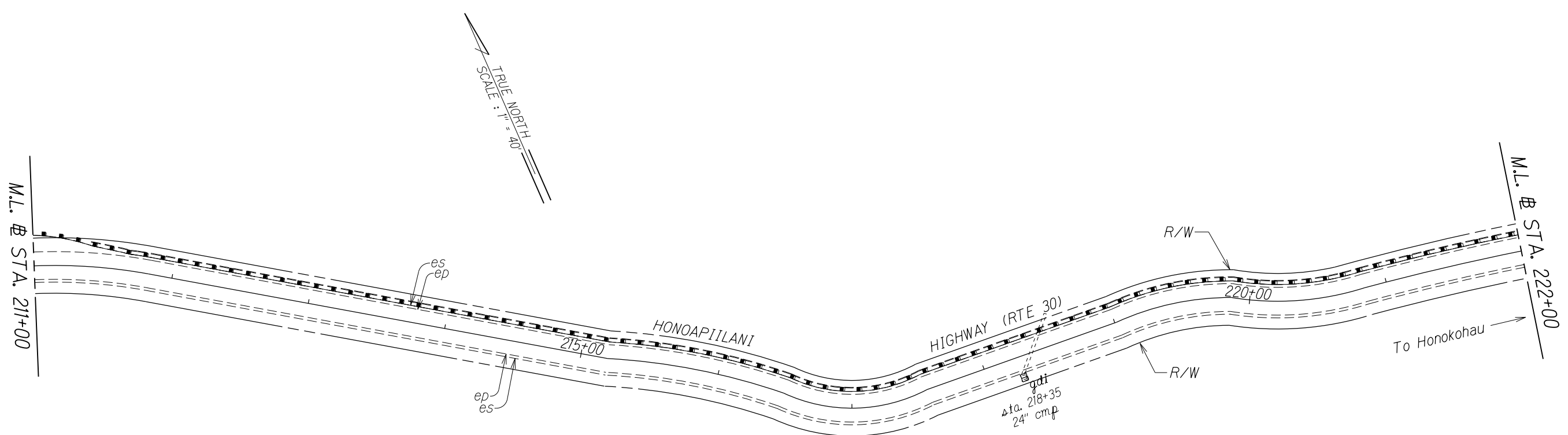
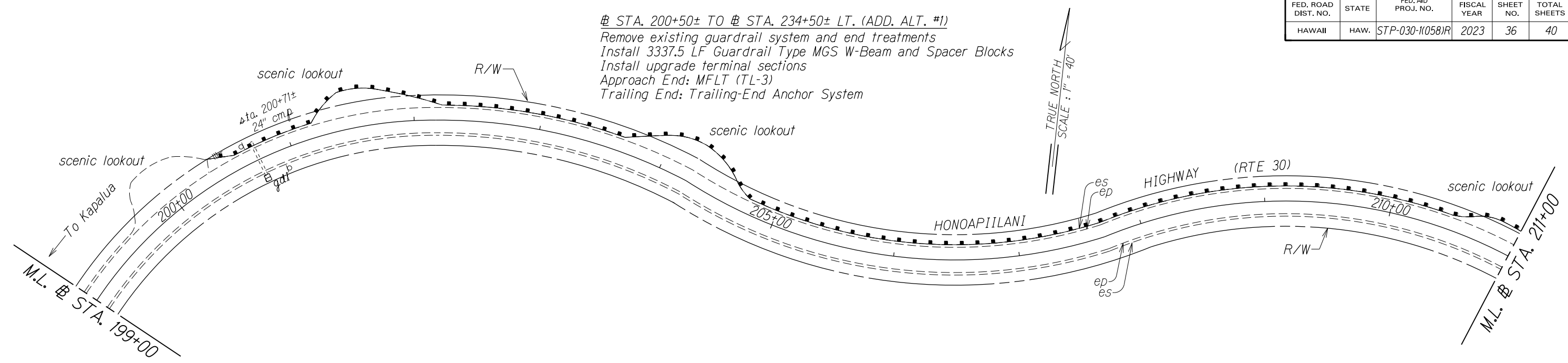

SURVEY PLOTTED BY	DATE
DRAWN BY	3/23
DESIGNED BY	
QUANTITIES BY	
CHECKED BY	

NOTE: Install New Type MGS standard 6-Ft. guardrail post or 8-Ft. guardrail post as required to adequately secure new guardrail system. Contractor shall abandon existing guardrail post in place as determined necessary to avoid damage to existing shoulder and/or slope area behind guardrail. Existing guardrail post to be abandoned in place shall be cut flush or below ground surface.

STATE OF HAWAII
 DEPARTMENT OF TRANSPORTATION
 HIGHWAYS DIVISION
ROADWAY PLANS
HONOAPIILANI HIGHWAY
GUARDRAIL & SHOULDER IMPROVEMENTS
 Vicinity of North Kihei Road to Hononana
 Federal-Aid Project No. STP-030-1(058)R
 Scale: 1" = 40' Date: March, 2023
 SHEET No. 16 OF 17 SHEETS

FED. ROAD DIST. NO.	STATE	FED. AID PROJ. NO.	FISCAL YEAR	SHEET NO.	TOTAL SHEETS
HAWAII	HAW.	STP-030-1(058)R	2023	37	40

± STA. 200+50± TO ± STA. 234+50± LT. (ADD. ALT. #1)

Remove existing guardrail system and end treatments
 Install 3337.5 LF Guardrail Type MGS W-Beam and Spacer Blocks
 Install upgrade terminal sections
 Approach End: MFLT (TL-3)
 Trailing End: Trailing-End Anchor System

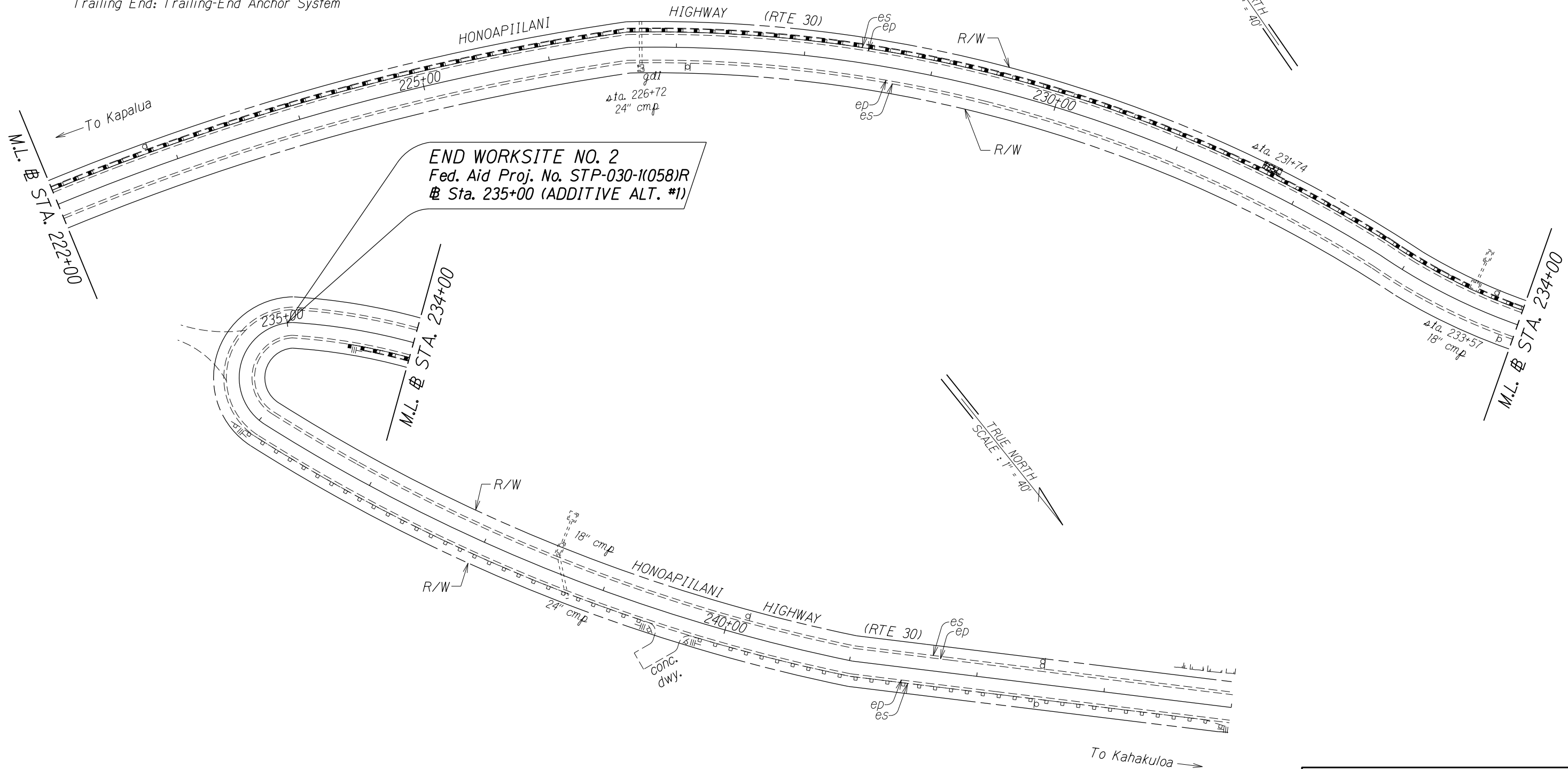

END WORKSITE NO. 2
 Fed. Aid Proj. No. STP-030-1(058)R
 ± Sta. 235+00 (ADDITIVE ALT. #1)

NOTE: Install New Type MGS standard 6-Ft. guardrail post or 8-Ft. guardrail post as required to adequately secure new guardrail system. Contractor shall abandon existing guardrail post in place as determined necessary to avoid damage to existing shoulder and/or slope area behind guardrail. Existing guardrail post to be abandoned in place shall be cut flush or below ground surface.

STATE OF HAWAII
 DEPARTMENT OF TRANSPORTATION
 HIGHWAYS DIVISION

ROADWAY PLANS

HONOAPIILANI HIGHWAY
GUARDRAIL & SHOULDER IMPROVEMENTS
 Vicinity of North Kihei Road to Hononana
 Federal-Aid Project No. STP-030-1(058)R

Scale: 1" = 40' Date: March, 2023

SHEET No. 17 OF 17 SHEETS

SURVEY PLOTTED BY	DATE
DRAWN BY	3/23
DESIGNED BY	
QUANTITIES BY	
CHECKED BY	

GUARDRAIL SUMMARY - BASE BID (MAKAI "OCEAN" SIDE)									
Project Guardrail Segment	Guardrail Type MGS (LF) (a)	Strong Post Thrie-Beam (LF) (a)	Type MGS Trans. Section (d)	End Terminal Treatment					Remarks (h)
				MASH Type A (e)	Modified Type I-A (e)	MFLT (TL-3) (f)	MSKT-SP-MGS8 (TL-3) (e)	Trailing-End Anchorage System (g)	
Sta 65+15± to 72+65± Lt. (b)	662.5			1		1			100' Type MGS with 8-Ft. Posts
Sta 72+85± to 79+85± Lt.	625.0			1				1	
Sta 81+20± to 83+55± Lt. (b)	137.5			1			1		100' Type MGS with 8-Ft. Posts
Sta 85+25± to 93+25± Lt.	712.5			1		1			
Sta 93+60± to 94+85± Lt.	50.0				1			1	
Sta 97+70± to 103+45± Lt.	475.0			1	1				
Sta 105+95± to 108+95± Lt.	200.0			2					
Sta 371+75± to 376+65± Rt.	400.0			1		1			
Sta 365+15± to 371+45± Rt.	562.5				1			1	
Sta 355+95± to 364+05± Rt.	712.5				2				
Sta 346+00± to 352+10± Rt.	200.0	325.0			1	1			Thrie-Beam length includes transitions
Sta 334+40± to 345+00± Rt.	887.5	100.0			1			1	Thrie-Beam length includes transitions
Sta 327+45± to 332+05± Rt.	362.5				2				
Sta 320+70± to 323+55± Rt.	187.5				2				
Sta 316+20± to 318+30± Rt.	112.5				2				
Sta 309+20± to 315+05± Rt. (b)	487.5				2				100' Type MGS with 8-Ft. Posts
Sta 303+70± to 307+05± Rt.	237.5				2				
Sta 297+20± to 300+30± Rt.	212.5				2				
Sta 290+45± to 295+55± Rt.	412.5			1	1				
Sta 286+45± to 290+05± Rt.	262.5			2					
Sta 279+85± to 284+05± Rt.	325.0			1	1				
Sta 270+55± to 277+80± Rt.	625.0				2				
Sta 261+45± to 265+55± Rt.	312.5			1	1				
Sta 251+85± to 255+12± Rt.	237.5		1		1				Exist. trailing end terminal to remain (19')
Sta 244+80± to 247+05± Rt.	125.0				2				
Sta 235+85± to 240+85± Rt.	400.0				2				
Sta 224+70± to 234+05± Rt.	837.5				1		1		
Base Bid (Makai) - Sub-Totals:	10,762.5	425.0	1	13	30	4	2	4	
Totals plus 10% Contingency:	11,850.0	475.0	1	14	33	4	2	4	

- (a) Length rounded up to nearest 12.5-Foot increment
- (b) Includes Type MGS with 8-Ft. Posts
- (c) Includes Thrie-Beam with 8 Ft. Posts
- (d) Type MGS transition section (±25 LF, Each)
- (e) Average limit of payment (±50 LF, Each)
- (f) Average limit of payment (±40.0 LF, Each)
- (g) Average limit of payment (±25 LF, Each)
- (h) Length of existing end treatments estimated
- (i) Bid Alternative Sub-Totals include 10% Contingency

SURVEY PLOTTED BY _____ DATE 3/23
 DRAWN BY _____
 NOTE BOOK DESIGNED BY LH
 QUANTITIES BY me/jay
 CHECKED BY [Signature]

STATE OF HAWAII
 DEPARTMENT OF TRANSPORTATION
 HIGHWAYS DIVISION
GUARDRAIL SUMMARY
HONOAPIILANI HIGHWAY
 GUARDRAIL & SHOULDER IMPROVEMENTS
 Vicinity of North Kihei Road to Hononana
 Federal-Aid Project No. STP-030-1(058)R
 Date: March, 2023
 SHEET No. 1 OF 2 SHEETS

GUARDRAIL SUMMARY - BASE BID (MAUKA "MOUNTAIN" SIDE)									
Project Guardrail Segment	Guardrail Type MGS (LF) (a)	Strong Post Thrie-Beam (LF) (a)	Type MGS Trans. Section (d)	End Terminal Treatment					Remarks (h)
				MASH Type A (e)	Modified Type 1-A (e)	MFLT (TL-3) (f)	MSKT-SP-MGS8 (TL-3) (e)	Trailing-End Anchorage System (g)	
Sta 69+55± to 71+30± Rt.	75.0			2					
Sta 75+45± to 77+45± Rt.	100.0			2					
Sta 80+75± to 83+25± Rt. (b)	150.0			2					50.0' Type MGS with 8-Ft. Posts
Sta 98+95± to 103+45± Rt. (b)	350.0			1	1				100.0' Type MGS with 8-Ft. Posts
Sta 371+90± to 375+75± Lt.	300.0			1		1			
Sta 365+95± to 367+55± Lt.	62.5				2				
Sta 363+20± to 364+05± Lt.	0.0				2				
Sta 355+95± to 360+05± Lt.	312.5				2				
Sta 347+50± to 350+75± Lt. (c)	0.0	325.0							50.0' Thrie-Beam with 8-Ft. Posts/New Connectors
Sta 335+95± to 338+05± Lt.	112.5				2				
Sta 327+45± to 329+05± Lt.	62.5			1	1				
Sta 321+20± to 324+30± Lt.	212.5				2				
Sta 309+45± to 314+30± Lt.	387.5				2				
Sta 304+75± to 306+30± Lt.	62.5				2				
Sta 298+45± to 300+05± Lt.	62.5				2				
Sta 286+95± to 289+55± Lt.	162.5				2				
Sta 279+95± to 283+05± Lt.	212.5				2				
Sta 270+95± to 272+45± Lt.	50.0				2				
Sta 262+45± to 263+20± Lt.	0.0				2				
Sta 258+30± to 259+90± Lt.	75.0		1		1				Exist. end terminal to remain (19')
Sta 253+95± to 255+12± Lt.	25.0		1		1				Exist. end terminal to remain (19')
Sta 225+85± to 228+10± Lt.	125.0				1		1		
Base Bid (Mauka) - Sub-Totals:	2,900.0	325.0	2	9	29	1	1	0	
Totals plus 10% Contingency:	3,200.0	362.5	2	10	32	1	1	0	

GUARDRAIL SUMMARY (ADDITIVE ALTERNATE #1)									
Project Guardrail Segment	Guardrail Type MGS (LF) (a)	Strong Post Thrie-Beam (LF) (a)	Type MGS Trans. Section (d)	End Terminal Treatment					Remarks (h)
				MASH Type A (e)	Modified Type 1-A (e)	MFLT (TL-3) (f)	MSKT-SP-MGS8 (TL-3) (e)	Trailing-End Anchorage System (g)	
Sta 78+00± to 86+60± Lt.	800.0		1			1			Connect new guardrail to exist. guardrail section
Sta 131+60± to 146+40± Lt.	1,412.5						1	1	
Sta 143+75± to 144+85± Rt.	50.0					1		1	
Sta 146+80± to 154+50± Lt.	712.5					1		1	
Sta 156+00± to 169+00± Lt.	1,237.5					1		1	
Sta 176+50± to 181+00± Lt.	375.0						1	1	
Sta 200+50± to 234+50± Lt.	3,337.5					1		1	
Totals:	7,925.0	0	1	0	0	5	2	6	
Totals plus 10% Contingency:	8,725.0	0	1	0	0	6	2	7	

GUARDRAIL SUMMARY (TOTAL QUANTITIES)									
Project Guardrail Segment (i)	Guardrail Type MGS (LF) (a)	Strong Post Thrie-Beam (LF) (a)	Type MGS Trans. Section (d)	End Terminal Treatment					
				MASH Type A (e)	Modified Type 1-A (e)	MFLT (TL-3) (f)	MSKT-SP-MGS8 (TL-3) (e)	Trailing-End Anchorage System (g)	
Base Bid Sub-Totals:	15,050.0	837.5	3	24	65	5	3	4	
Additive Alternate #1 Bid Sub-Totals:	8,725.0	0.0	1	0	0	6	2	7	
Totals:	23,775.0	837.5	4	24	65	11	5	11	

- (a) Length rounded up to nearest 12.5-Foot increment
- (b) Includes Type MGS with 8-Ft. Posts
- (c) Includes Thrie-Beam with 8 Ft. Posts
- (d) Type MGS transition section (±25 LF, Each)
- (e) Average limit of payment (±50 LF, Each)
- (f) Average limit of payment (±40.0 LF, Each)
- (g) Average limit of payment (±25 LF, Each)
- (h) Length of existing end treatments estimated
- (i) Bid Alternative Sub-Totals include 10% Contingency

STATE OF HAWAII
DEPARTMENT OF TRANSPORTATION
HIGHWAYS DIVISION

GUARDRAIL SUMMARY
HONOAPIILANI HIGHWAY
GUARDRAIL & SHOULDER IMPROVEMENTS
Vicinity of North Kihei Road to Hononana
Federal-Aid Project No. STP-030-1(058)R

Date: March, 2023

SHEET No. 2 OF 2 SHEETS

SURVEY PLOTTED BY: _____ DATE: 3/22
 DRAWN BY: _____
 NOTE BOOK DESIGNED BY: LH
 QUANTITIES BY: me/jay
 CHECKED BY: Ngomsum/dg

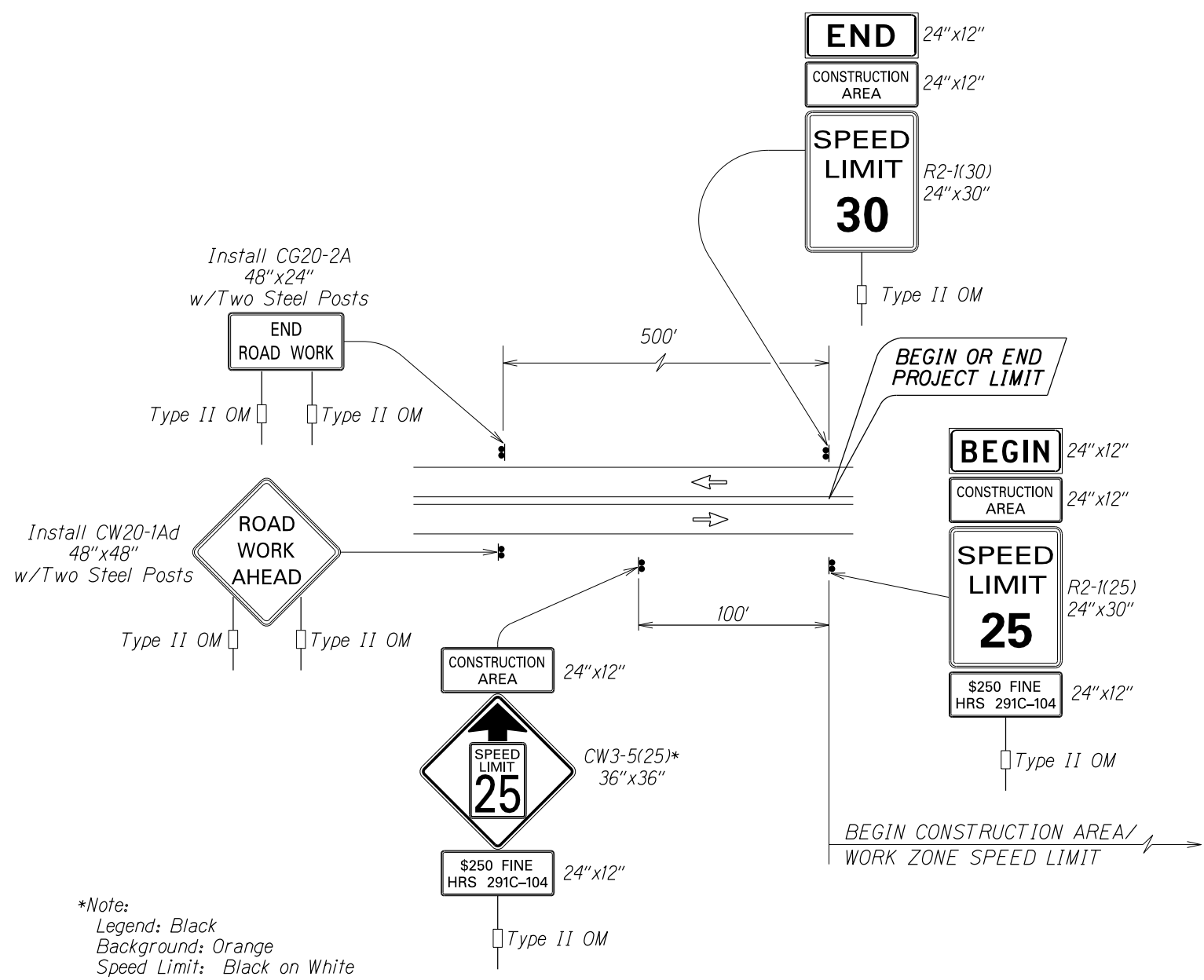

*Note:
 Legend: Black
 Background: Orange
 Speed Limit: Black on White

**TYPICAL DETAIL FOR CONSTRUCTION SIGNS
 ON TWO LANE OR MULTILANE UNDIVIDED LOW SPEED HIGHWAY**

Work Zone Note:

- Contractor shall submit a Traffic Control Plan (TCP) at least 15 working days before the start of work per Section 645 of the Standard Specifications.
- This Work Zone Sign Plan is intended for use on long-term stationary work zones/construction phases (3 days or more). All work zones or construction phases less than 3 days duration will use Traffic Control Plans shown in Section 645 of the Standard Specifications.
- All existing regulatory speed limit signs with posts within the work zone/project limits shall be removed and replaced with work zone speed limit sign assemblies (R2-1(25) and R2-5b(25) with "CONSTRUCTION AREA" and "\$250 FINE HRS 291C-104" Supplemental Signs).
- Construction sign assemblies shall be installed on both the approaching and trailing ends of each work zone as shown on this plan.
- Each construction warning sign shall have a minimum of two (2) Type II OM. Each work zone speed limit assembly shall have a minimum of one (1) Type II OM. Installation of each Type II OM shall be considered incidental to Item No. 631.3000, Construction Sign with Post.
- Upon the completion of all physical work or as directed by the Engineer, all construction signs and work zone speed limit assemblies shall be removed. All speed limit signs and posts that were existing at the start of the project within the work zone/project limits shall be restored back to their original locations and configurations.
- Placement of construction signs shall not obstruct the path of pedestrians and bicyclists.
- The removal and restoration of existing regulatory speed limit signs shall be considered incidental to Item No. 631.3000, Construction Sign with Post.
- The installation, maintenance and removal of work zone speed limit sign assemblies shall be paid for under Item No. 631.3000, Construction Sign with Post.
- The work zone speed limit signs shall be new and become the property of the Contractor.

EXISTING POSTED SPEED LIMIT (MPH)	XX-NEW CONSTRUCTION AREA SPEED LIMIT (MPH)	D-REDUCED SPEED LIMIT SIGN SPACING TO FIRST CONSTRUCTION AREA SPEED LIMIT SIGN (FEET)
≤ 25	EXIST. SPEED LIMIT TO REMAIN	
30	25	100
35	25	175
40	30	175

SURVEY PLOTTED BY: DATE: 3/23
 DRAWN BY: LH
 DESIGNED BY: LH
 QUANTITIES BY: X.dgn
 CHECKED BY: X.dgn
 ORIGINAL PLAN: 15/21/08 /usr2/lyme/stve/const/_signs/constsignswy2/mispadgn

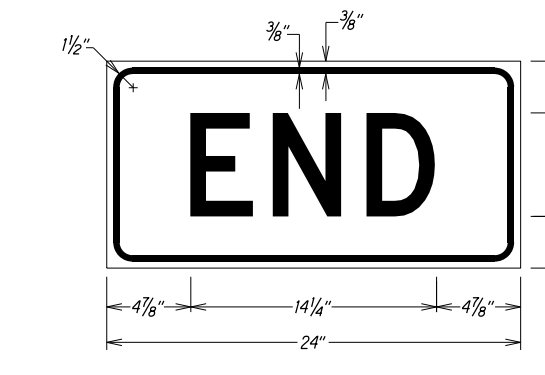
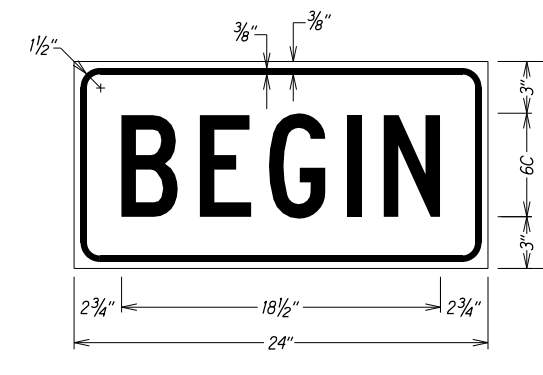
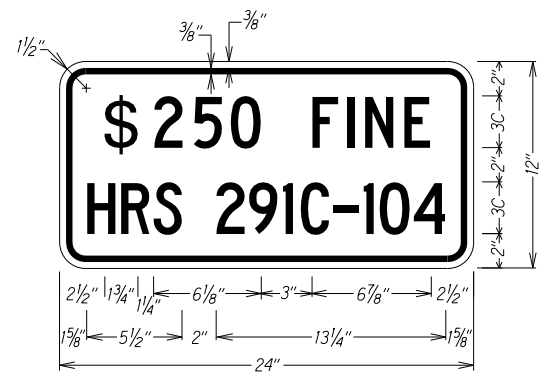
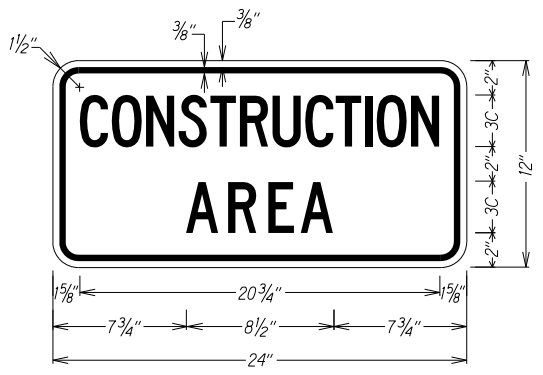

STATE OF HAWAII
 DEPARTMENT OF TRANSPORTATION
 HIGHWAYS DIVISION

**LOW SPEED UNDIVIDED HIGHWAY
 WORK ZONE SIGNING PLAN, NOTES & DETAILS**

HONOAPIILANI HIGHWAY GUARDRAIL & SHOULDER IMPROVEMENTS
 Vicinity of North Kihei Road to Hononana
 Federal-Aid Project No. STP-030-1(058)R
 Not To Scale Date: March, 2023

SHEET No. 1 OF 1 SHEETS